



Three-Phase Hybrid Inverter

10 / 12 / 15 / 20kW

User Manual

Address: Eyüp Sultan Mh. Dercan Sk. No 3 Sancaktepe / İSTANBUL 34885

Tel: [+90 850 201 68 77](tel:+908502016877)

Fax: [+90 216 420 35 29](tel:+902164203529)

Email: info@tuncmatik.com

Technical service: support@tuncmatik.com

Sales & Marketing: sales@tuncmatik.com

International sales: export@tuncmatik.com

Document number

Issue 01 | 11.05.2026

English

CONTENT

1	About this manual	1
1.1	Copyright declaration	2
1.2	Presentation of warnings	2
1.3	Presentation of action instructions	3
1.4	Note	3
2	Basic safety information	4
2.1	Safety instructions	4
2.2	Symbols and signs	9
3	Product characteristics	11
3.1	Product information	11
3.2	Size description	13
3.3	Function characteristics	13
4	Installation	14
4.1	Installation notes	14
4.2	Checking Before Installation	14
4.3	Product Overview	15
4.4	Component List	17
4.5	Tools	18
4.6	Installation Environment	19
4.7	Determining the Installation Position	20
4.8	Unpacking the inverter	20
4.9	Installation of the inverter	21
5	Electrical Connections	23
5.1	Wire instructions	24
5.2	Connecting PGND Cables	25
5.3	Battery Connection	27
5.4	PV Connection	30
5.5	Load connection	33
5.6	Grid connection	34

5.7	GEN connection	36
5.8	System electrical topology	37
5.9	External communication interface	38
5.10	Wiring Diagram Overview	54
6	Buttons and indicator lights	56
6.1	Buttons	56
6.2	Indicator lights and status	56
7	Operation	57
7.1	Double Check	57
7.2	First Time Setup (IMPORTANT!)	57
7.3	Menu	66
7.4	Power-On Step	98
7.5	Power-off Step	99
8	Troubleshooting	100
9	Datasheet	110
10	Quality Assurance	113

1 About this manual

This Installation and user manual (hereinafter referred to as the manual) describes the installation, electrical connection, commissioning, maintenance and fault elimination procedures of following products:

THY-T10K-LV, THY-T12K-LV, THY-T15K-LV, THY-T20K-LV

THY-T10/12/15/20K-LV inverter is a Three-phase photovoltaic energy storage inverter integrating grid connected photovoltaic inverter and battery energy storage, and the manual will subsequently simplify to the system as “the inverter”.

- ▶ Carefully read this manual before use!
- ▶ Treat this manual as an integral component of the device.
- ▶ Keep this manual in close proximity to the device, including when it is handed over to another user or moved to a different location.

This manual contains important safety information on installation, operation and maintenance of the device.

- ▶ Read and observe all given safety information.

The products, services or features you purchased shall be subject to the company 's commercial contracts and terms. All or part of the products and services described in this document may not within the scope of your purchase. Unless additional terms and conditions in your contract, the company does not make any statement or guarantee on the contents of this document.

- ▶ Target Group

This manual is intended for qualified electrical technical personnel who are responsible for inverter installation and commissioning in the PV power system and PV plant operator.

1.1 Copyright declaration

The copyright of this manual is owned by Tuncmatik. It may not be copied – neither partially nor completely – by companies or individuals (including software, etc.) and must not be reproduced or distributed in any form, or with the appropriate means.

TUNCMATIK reserves the right to final interpretation. This manual may be amended following feedback from users or customers.

1.2 Presentation of warnings

This manual contains information on safe operation and uses symbols to ensure the safety of persons and property as well as the efficient operation of the inverter.

- ▶ Read through the following symbol explanations carefully in order to prevent injury or property damage.

1.2.1 Warnsymbol

	<p>The general danger symbol warns of risk of serious injury when used with the signal words CAUTION, WARNING, and DANGER.</p>
---	--

1.2.2 Signalwords

<p>DANGER</p>	<p>Indicates a hazardous situation which, if not avoided, will result in death or serious injury.</p>
<p>WARNING</p>	<p>Indicates a hazardous situation which, if not avoided, could result in death or serious injury.</p>
<p>CAUTION</p>	<p>Indicates a hazardous situation which, if not avoided, could result in minor or moderate injury.</p>
<p>NOTICE</p>	<p>Indicates a danger that results in damage to or destruction of the inverter.</p>

1.2.3 Sectional warnings

Sectional warnings refer to a complete section and are structured as follows:

 WARNING	
Type and source of danger	
Consequences for non-observance	
▶ Avoiding the danger	

1.2.4 Embedded warnings

Embedded warnings are part of an action sequence and are placed right before the dangerous step.

WARNING Combination of type/source of danger, consequences for non-observance and avoiding the danger.

1.3 Presentation of action instructions

This table shows the sequence of Action steps:

Symbol	Function
✓	This describes an action requirement
1. 2. 3.	This is the sequence of action steps that must be followed step by step
▶	This is a single action step
↪	This describes the result of the action

1.4 Note

Notes are presented in a grey bar.

▶ Provides tips essential to the optimal operation of the product.

2 Basic safety information



- ▶ If you have any questions or problems after reading the following information, please contact TUNCMATIK

This chapter details the safety information pertaining to the installation and operation of the device.

2.1 Safety instructions

Read and understand the instructions of this manual, and be familiar with relevant safety symbols in this chapter, then start to install and troubleshoot the equipment.

According to the national and state requirements, before connecting to the electrical grid, you must get permission from the local electrical grid operation can only be performed by qualified electrical engineer.

Please contact the nearest authorized service center if any maintenance or repair is needed. Contact your distributor for the information of the nearest authorized service center. Do NOT repair it by yourself, it may cause injury or property damage.

Before installing and maintaining the equipment, you should turn the DC switch OFF to cut off the high voltage DC of the PV array. You can also turn the switch in the PV combiner box off to cut off the high voltage DC. When the battery needs to be installed, please confirm the positive and negative terminals of the battery and turn off the battery. Otherwise, serious injury may be caused.

2.1.1 Qualified persons

The customer must make sure the operator has the necessary skill and training to do his/her job. Staff in charge of using and maintaining the equipment must be skilled, aware and mature for the described tasks and must have the reliability to correctly interpret what is described in the manual. For safety reason only a qualified electrician, who has received training or has demonstrated skills and knowledge in construction and in operation of this unit, can install this inverter. Tuncmatik does not take any responsibility for the property destruction and personal injury because of any incorrect use.

2.1.2 Installation requirements

Please install inverter according to the following section. Fix the inverter on an appropriate object with enough load bearing capacity (such as walls, PV racks etc.), and ensure that inverter is vertical placed. Choose a place suitable for installing electrical devices. And assure there is enough fire exit space, convenient for maintenance. Maintain proper ventilation to ensure enough air cycle to cool the inverter.

2.1.3 Transport requirements

If you find packing problems that may cause the damage of the inverter, or find any visible damage, please immediately notice the responsible transportation company. You can ask solar equipment installation contractor or Tuncmatik for help if necessary.

Transport of the equipment, especially by road, must be carried out by suitable ways and means for protecting the components (in particular, the electronic components) from violent shocks, humidity, vibration, etc.

2.1.4 Labels on the equipment

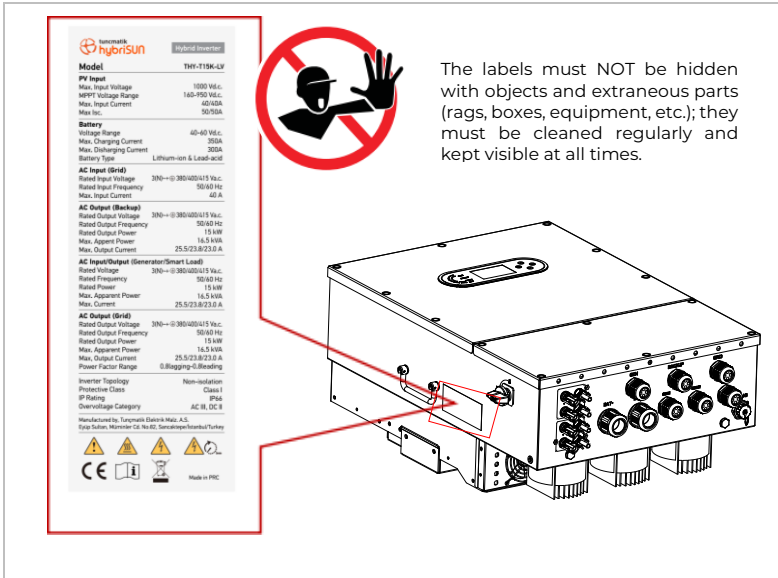

2.1.5 Electric connection

Please comply with all the current electrical regulations about accident prevention in dealing with the TUNCMATIK inverter.

DANGER

- ▶ Before the electrical connection, make sure to use opaque material to cover the PV modules or to disconnect PV array DC switch. Exposure to the sun, PV array will produce a dangerous voltage!

⚠ WARNING

- ▶ All installation accomplished only by professional electrical engineer!
- ▶ Must be trained!
- ▶ Completely read the manual operation and understand relevant matter.

NOTICE

- ▶ Get permission from the local electrical grid operator, complete all electrical connections by professional electrical engineer, then connect inverter to electrical grid.

- ▶ It's forbidden to remove the tamper evident label, or open the inverter. Otherwise TUNCMATIK will not provide warranty or maintenance!

2.1.6 Operation**⚠ DANGER**

- ▶ Touching the electrical grid or the terminal of the equipment may lead to electrocution or fire!
- ▶ Don't touch the terminal or conductor connected to the electrical grid.
- ▶ Pay attention to any instructions or safety documents related to grid connection.

NOTICE

- ▶ Some internal components will be very hot when inverter is working. Please wear protective gloves!

2.1.7 Maintenance and repair

DANGER

- ▶ Before any repair work, turn OFF the AC circuit breaker between the inverter and electrical grid first, then turn off the DC switch.
- ▶ After turning off the AC circuit breaker and DC switch, wait for 5 minutes at least before carrying out any maintenance or repair work.

NOTICE

- ▶ Inverter should work again after removing any faults. If you need any repair work, please contact with the local authorized service center.
- ▶ Do not open the internal components of inverter without authorization, otherwise Tuncmatik does not take any responsibility for the property destruction and personal injury.

2.1.8 EMC / noise level of inverter

Electromagnetic compatibility (EMC) refers to that one electrical equipment functions in a given electromagnetic environment without any trouble or error, and impose no unacceptable effect upon the environment. Therefore, EMC represents the quality characters of an electrical equipment. The inherent noise-immune character: immunity to internal electrical noise. External noise immunity: immunity to electromagnetic noise of external system. Noise emission level: influence of electromagnetic emission upon environment.

DANGER

Electromagnetic radiation from inverter may be harmful to health!

- ▶ Please do not continue to stay around the inverter in less than 20 cm when inverter is working.

2.2 Symbols and signs

CAUTION

- ▶ Caution of burn injuries due to hot enclosure!
- ▶ You can only touch the screen and pressing key of the inverter while it's working.

NOTICE









- ▶ PV array should be grounded in accordance to the requirements of the local electrical grid operator!
- ▶ We suggest that all PV module frames and inverter are reliably grounded to protect the PV system and personnel security.

WARNING

- ▶ Ensure input DC voltage < Max. DC voltage. Over voltage may cause permanent damage to inverter or other losses, which will not be included in warranty!

2.2.1 Signs on the inverter

There are some symbols which are related to security on the inverter. Please read and understand the content of the symbols, and then start the installation.

Symbol	Description
	This symbol indicates a hazardous situation which could result in injuries, if not avoided.
	Residual voltage is present in the inverter! Before opening the inverter, you should wait five minutes to ensure that the capacitor has been fully discharged.
	Caution! risk of electric shock.
	Caution! Hot surface.
	The product is compliant with EU guidelines
	Earthing point
	Please read this manual before install the inverter.
	Positive pole and negative pole of the input voltage (DC).
IP66	This indicates the degree of protection of the equipment according to IEC standard 70-1. (EN 60529 June 1997)
	This side up, the inverter must always be transported, handled and stored in such a way that the arrows always point upwards.

3 Product characteristics

3.1 Product information

The inverter is a three-phase photovoltaic energy storage inverter integrating grid connected photovoltaic inverter and battery energy storage.

The inverter has a variety of built in operating modes to suit the diverse user needs.

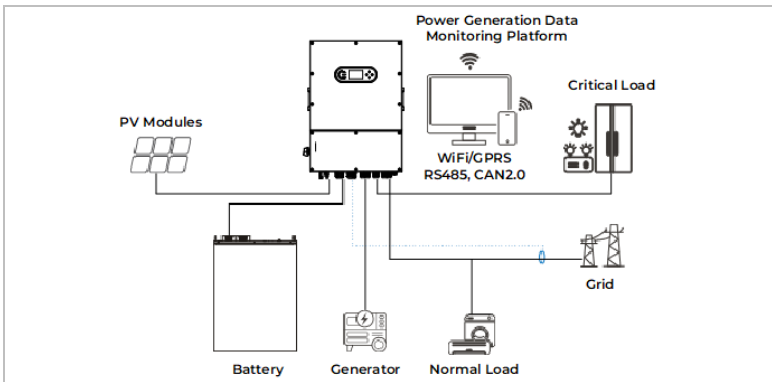

Figure 3-1(a) The inverter on-grid system diagram

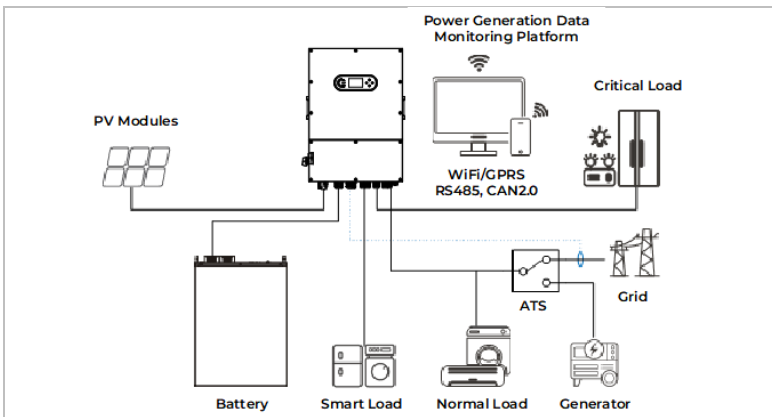

Figure 3-1(b) The inverter off-grid system diagram

(Grid port connect Generator via ATS; Generator port connects Smart Load)

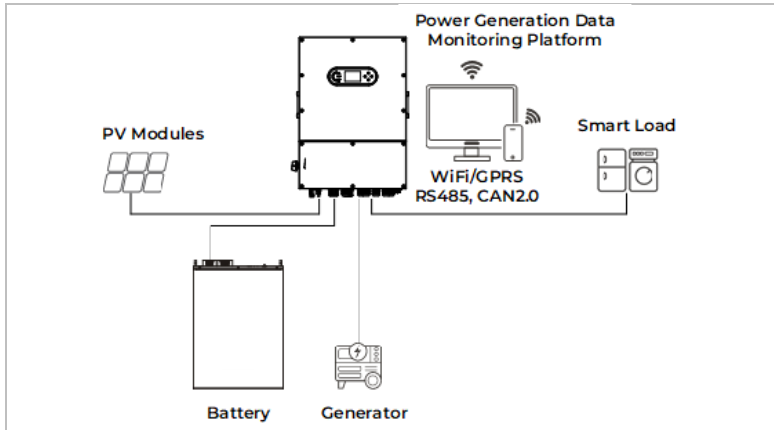

Figure 3-1(c) The inverter off-grid system diagram.
(only Generator; Backup port connects Smart Load)

The inverter can provide a complete solution in the period of rising energy costs such as oil and coal; The energy subsidy of photovoltaic grid-connected system keeps falling. In the period of continuous power supply and emergency power supply demand in mountainous areas or base stations without power grid.

The inverter can be connected to a generator, as shown in figure 3-1(a), to timely control the generator to replace the grid and continue working when the grid is disconnected.

In addition, the grid port of the inverter can also be directly connected to the generator, while the generator port is connected to the smart load, as shown in figure 3-1(b).

Finally, the backup port of the inverter can also be connected to smart load, but an additional relay needs to be connected for control, as shown in figure 3-1(c). Please refer to section 5.9.2 for the method of connecting external relays.

3.2 Size description

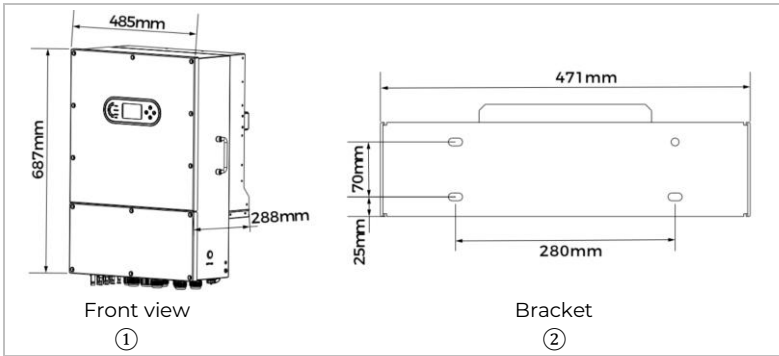

Figure 3-2 Size chart

3.3 Function characteristics

- ▶ Support 200% overload for 10 seconds.
- ▶ Supports 2 DC: AC ratio to connect more PV capacity
- ▶ Max. 350A charge/discharge current capability.
- ▶ Wide MPPT voltage range (160-950 V).
- ▶ Automatic switchover time of 4ms, provides seamless switching between grid and backup.
- ▶ The Emergency Power Supply (EPS) mode can support inductive loads. Such as, air conditioners or refrigerators.
- ▶ Support diesel generators for energy storage and home power, during grid power outage.
- ▶ Multiple inverters in parallel to build a microgrid.
- ▶ Smart monitoring, RS485/Wi-Fi/Bluetooth/GPRS(Optional).

4 Installation

4.1 Installation notes

DANGER

- ▶ Do not install the inverter on flammable material.
- ▶ Do not install the inverter in an area used to store flammable or explosive material.

CAUTION

- ▶ The enclosure and heat sink are very hot while the inverter is working, therefore do not install the inverter in places where you might touch them inadvertently.

NOTICE

- ▶ Consider the weight of inverter when transporting and moving the inverters.
- ▶ Choose an appropriate mounting position and surface.
- ▶ Assign at least two persons to install the inverter.

4.2 Checking Before Installation

4.2.1 Checking Outer Packing Materials

Packing materials and components may be damaged during transportation. Therefore, check the outer packing materials before installing the inverter. Check the outer packing materials for damage, such as holes and cracks. If any damage is found, do not unpack the inverter and contact the dealer as soon as possible. You are advised to remove the packing materials within 24 hours before installing the inverter.

4.2.2 Checking Deliverable

After unpacking the inverter, check whether deliverable is intact and complete. If any damage is found or any component is missing, contact the dealer.

- ▶ Please see the packing list for components and mechanical parts that should be delivered.

4.3 Product Overview

The inverter is 100% strictly inspected before package and delivery. It is forbidden to put the inverter upside down during delivery.

⚠ CAUTION

- ▶ Please check the product package and fittings carefully before installation.

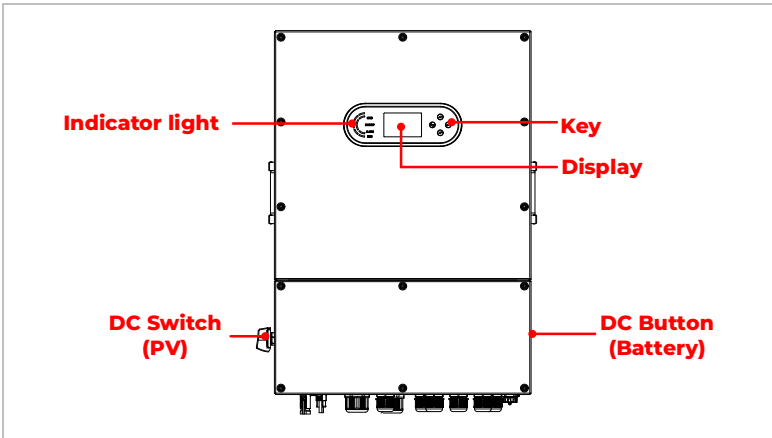

Figure 4-1 Front side view

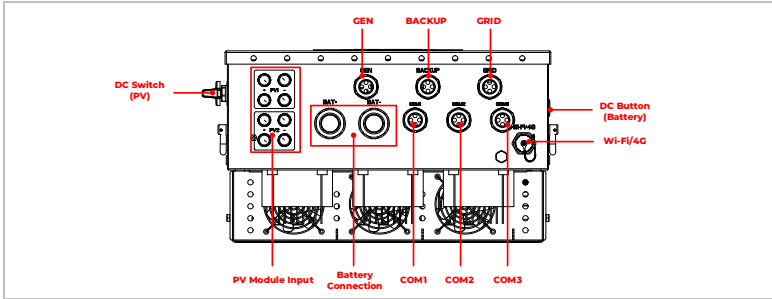

Figure 4-2 Bottom side view

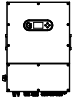



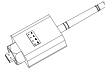







Table 4-1 Product Component Description



Name	Description
1. Indicator light	Indicates the operating status of the inverter.
2. LCD	Display detailed information of the inverter
3. Key	Used for controlling inverters
4. DC Switch (PV)	This is the DC disconnect switch for the PV.
5. DC Button (Battery)	This is the DC button for the Battery function
6. COM1	Used for RJ45 connection inside wiring box
7. COM2	Used for RJ45 connection inside wiring box
8. COM3	Used for 12 PIN terminal block connection inside wiring box
9. GEN	Conduit for AC conductors to generator should be connected here.
10. BACKUP	Conduit for AC conductors to backup loads should be connected here.
11. GRID	Conduit for AC conductors to the main service panel should be connected here.
12. PV Module Input	Conduit for PV conductors should be connected here.
13. Battery Connection	Conduit for Battery conductors should be connected here.
14. Wi-Fi/4G	Connect the datalogger

4.4 Component List

Check the equipment before installation. Please make sure nothing is damaged in the package. You should have received the items in the following package:

Table 4-2 Product component list



NO.	Image	Description	Quantity pcs
01		Inverter module	1
02		Wall bracket	1
03		M8*80 Expansion bolt	4
04		M6*14 Hexagon screw	5
05		Datalogger	1
06		PV+ input terminal	4+1(spare)
07		PV- input terminal	4+1(spare)
08		Metal terminals secured to PV+ input power cables	4+1(spare)
09		Metal terminals secured to PV- input power cables	4+1(spare)
10		Parallel operating communication cable (1.5m)	1
11		PCC CT	3
12		Installation specification check list	1







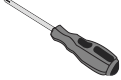
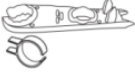

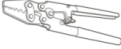
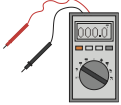
13		Outgoing inspection report	1
14		Quick installation guide	1
15		User manual	1

4.5 Tools

Prepare tools required for installation and electrical connections.

Table 4-3 Tools required for installation and electrical connections.

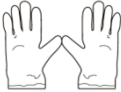
NO.	Tool	Model	Function
1		Hammer drill Recommend drill diameter 10mm	Used to drill holes on the wall.
2		Cross screwdriver	Remove and install AC terminal screws
3		Removal tool	Remove PV terminal
4		Wire stripper	Strip wire
5		Crimping tool	Used to crimp power cables
6		Multi-meter	Used to test electrical polarity and voltage

NO.	Tool	Model	Function
7		Adjustable wrench (Max. 3/4-inch open end)	Used to tighten expansion bolts
8		Socket Wrench	Used to tighten hex screw.
9		RJ45 crimping tool	Used to crimp RJ45 cables
10		Marker	Used to mark signs
11		Measuring tape	Used to measure distances
12		Level	Used to ensure that the rear panel is properly installed
13		Gloves	Personal protective equipment
14		Safety goggles	Operators wear
15		Anti-dust respirator	Operators wear

4.6 Installation Environment

- ▶ Choose a dry, clean, and tidy place, convenient for installation.
- ▶ Ambient temperature range: -30°C ~ 60°C.
- ▶ Relative humidity: 0 ~ 100% (non-condensed).
- ▶ The inverter shall be installed in a well-ventilated place.
- ▶ No flammable or explosive materials close to the inverter.

- ▶ The AC overvoltage category of the inverter is category III.
- ▶ Maximum altitude: 4000m.

4.7 Determining the Installation Position

Determine an appropriate position for installing the inverter. Comply with the following requirements when determining the installation position.

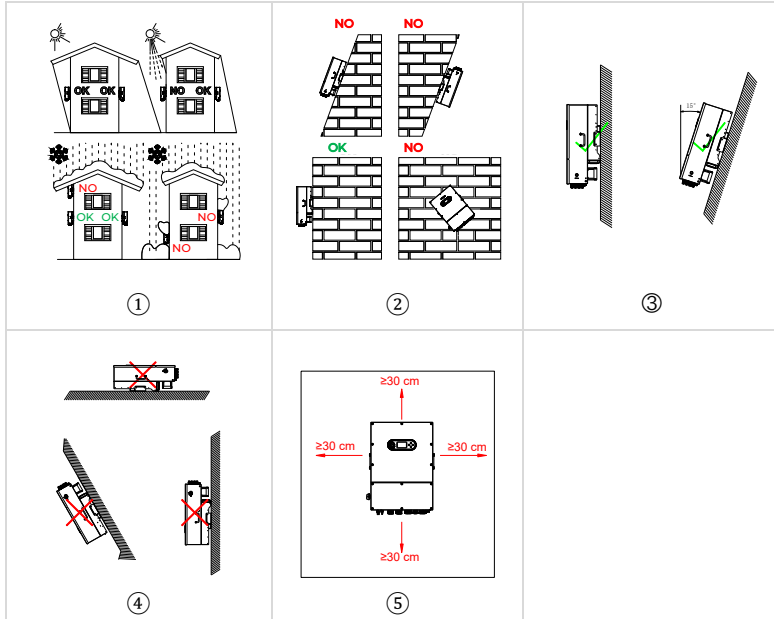

Figure 4-3 Installation Position of the inverter

4.8 Unpacking the inverter

Step 1 Open the packaging, insert hands into the slots on both sides of the inverter and hold the handles, as shown in figure 4-4.

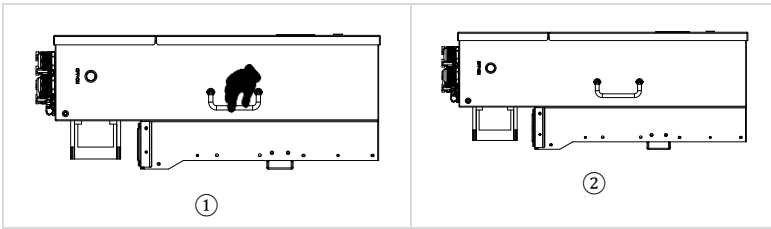

Figure 4-4 Moving the inverter

Step 2 Lift the inverter from the packing case and move it to the installation position.

NOTICE

- ▶ To prevent device damage and personal injury, keep balance when moving the inverter because the inverter is heavy.
- ▶ Do not put the inverter with its wiring terminals contacting the floor because the power ports and signal ports are not designed to support the weight of the inverter. Place the inverter horizontally.
- ▶ When placing the inverter on the floor, put foam or paper under the inverter to protect its shell.

4.9 Installation of the inverter

Step 1 Determine the positions for drilling holes, ensure the hole positions are level, then mark the hole positions using a marker pen, as shown in Figure 4-5①.

Step 2 Use the hammer drill to drill holes on the wall (diameter $\Phi 8$ mm). When drilling, keep the hammer drill perpendicular to the wall and drill slightly deeper than the length of the expansion pipe. After drilling, please check whether the hole position is suitable with the back plate. If the error is too large, please reposition the hole, as shown in Figure 4-5②.

Step 3 Slowly hammer the expansion screw into the drilled hole. Position the back plate well, place the shrapnel and flat pad, and fix the back plate with hexagon nut, as shown in Figure 4-5③.

Step 4 Hang the inverter on the back plate, as shown in Figure 4-5④.

Step 5 Lock the inverter and the back plate with M5 hex screw, you can secure the inverter to the rear panel, as shown in Figure 4-5⑤.

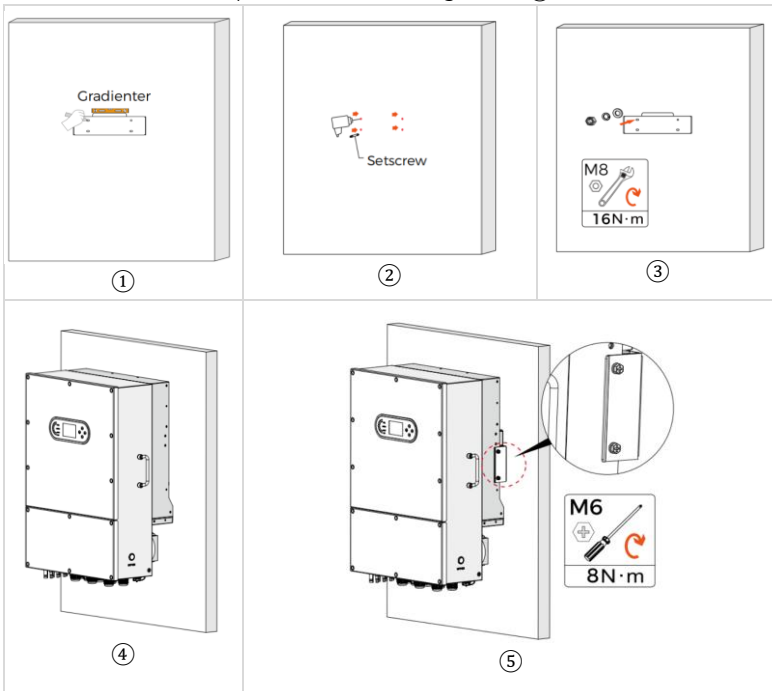

Figure 4-5 Installing the inverter

5 Electrical Connections

Before performing electrical connections, ensure that the DC switch is off. Since the stored electrical charge remains in a capacitor after the DC switch is turned off, it's necessary to wait for at least 5 minutes for the capacitor to be electrically discharged.

The inverter is intended to be used in PV system with battery storage. If not used as intended, the protection provided by the equipment may be impaired.

NOTICE

- ▶ Installation and maintenance of inverter, must be operated by professional electrical engineer.
- ▶ Wear rubber gloves and protective clothing (protective glasses and boots) when working on high voltage/high current systems such as inverter and battery systems.

DANGER

- ▶ PV modules will generate electric energy when exposed to sunlight and may cause electrical shock hazard. Therefore, before connecting DC input power cable, make sure to use opaque material to cover the PV modules.

- ▶ For the inverter, open-circuit voltage (Voc) of module arrays connected in series must be $\leq 1000V$.

The connected PV modules must have an IEC 61730 Class A rating.

- ▶ The DVC is the voltage of a circuit which occurs continuously between any two live parts in the worst case rated operating condition when used as intended.

Table 5-1 The decisive voltage class (DVC)

Interface	DVC
PV input port	DVC-C
Grid connection port	DVC-C
Battery input port	DVC-B
Load connection port	DVC-C
Generation input port	DVC-C
USB/Wi-Fi interface	DVC-A
COM interface	DVC-A

5.1 Wire instructions

Table 5-2 Cable description

Cables Type	Purpose	Connection Points
Ground Cables	Grounding conductors for the system	From the main grounding bar to the grounding point on the side of the inverter.
Battery Cables	Battery DC connection to the inverter	From the battery (+) and (-) terminals to the inverter BAT+ and BAT- terminals
PV Cables	PV DC connection to the inverter	From the PV array to the PV+ and PV- terminals in the inverter
AC Backup Cables	Inverter AC connection to the backup load	From the backup loads to the inverter AC-BACKUP port R/S/T/N/PE terminals
AC Grid Cables	Inverter AC connection to the Grid	From the grid to the inverter AC-Grid port R/S/T/N/PE terminals
AC GEN Cables	Inverter AC connection to the generator	From the generator to the inverter AC-Gen port R/S/T/N/PE terminals

5.2 Connecting PGND Cables

Connect the inverter to the grounding electrode using protection ground (PGND) cables for grounding purpose.

NOTICE

- ▶ The inverter is transformer-less, requires the positive pole and negative pole of the PV array are not grounded. Otherwise, it will cause inverter failure. In the PV power system, all non-current carrying metal parts (such as: PV module frame, PV rack, combiner box enclosure, inverter enclosure) should be connected to earth.
- ▶ The protective grounding of the chassis shell cannot replace the PGND cable of the AC LOAD Port. Ensure that the two PGND cables are reliably connected.
- ▶ When multiple inverters are deployed, ensure that the protective ground points of all inverters are equipotential connected.

The PGND cables are prepared ($\geq 4\text{mm}^2$ outdoor power cables are recommended for grounding purposes), the color of cable should be yellow-green.

Procedure:

Step 1 Remove the insulation layer with an appropriate length by using a wire stripper, as shown in Figure 5-1①.

Step 2 Insert the exposed core wires into the OT terminal and crimp them by using a crimping tool, as shown in Figure 5-1②.

Step 3 Install the crimped OT terminal, flat washer and M6 screw. Tighten the screw to a torque of $8\text{ N} \cdot \text{m}$. by using an Allen wrench, as shown in Figure 5-1③.

- ▶ L3 is the length between the insulation layer of the ground cable and the crimped part. L4 is the distance between the crimped part and core wires protruding from the crimped part.
- ▶ The cavity formed after crimping the conductor crimp strip shall wrap the core wires completely. The core wires shall contact the terminal closely.

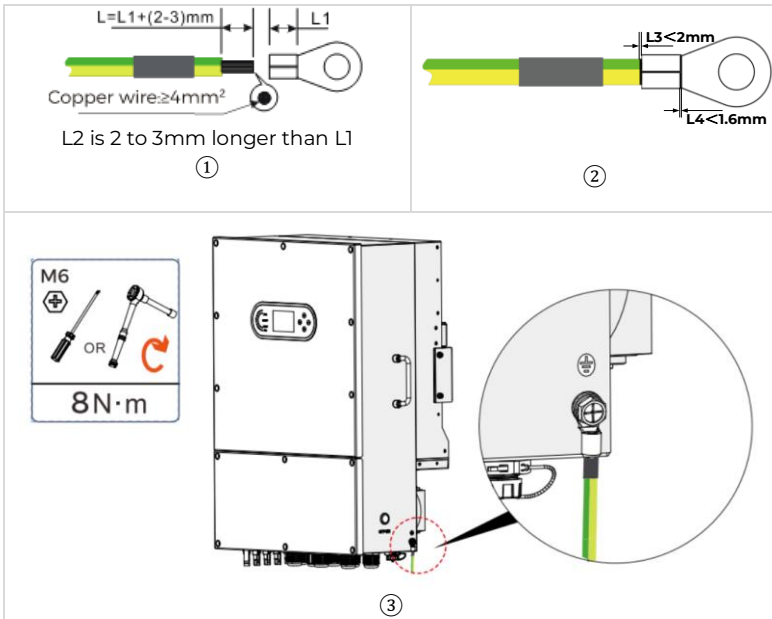

Figure 5-1 Connecting PGND cable

5.3 Battery Connection

Procedure:

Step 1 Select proper battery cable types and specifications based on Table 5-3. Remove cable glands from the positive and negative connectors. Connect the cable through the BAT port, and pay attention to the correct polarity, as shown in Figure 5-2(a)①

Table 5-3 Recommended battery cables for different models

Model	Cross-sectional area of cables
THY-T10K-LV	70mm ² (2/0 AWG)
THY-T12K-LV	
THY-T15K-LV	50mm ² (1/0 AWG) × 2
THY-T20K-LV	

- ▶ The cross-sectional area of the cable can be determined based on the maximum operating current at the battery port, with a minimum selection of 0.3 mm²/A. It should also be noted that the cable cross-section must meet the requirements of the $\Phi 8$ OT terminals.

Step 2 Remove the insulation layer with an appropriate length from the positive and negative power cables by using a wire stripper, insert the stripped positive and negative power cables into the positive and negative metal terminals respectively and crimp them using a crimping tool, as shown in Figure 5-2(a)②.

Step 3 Fix the battery cables to the BAT+ and BAT- terminals of the inverter with M8 screws, as shown in Figure 5-2(a)③.

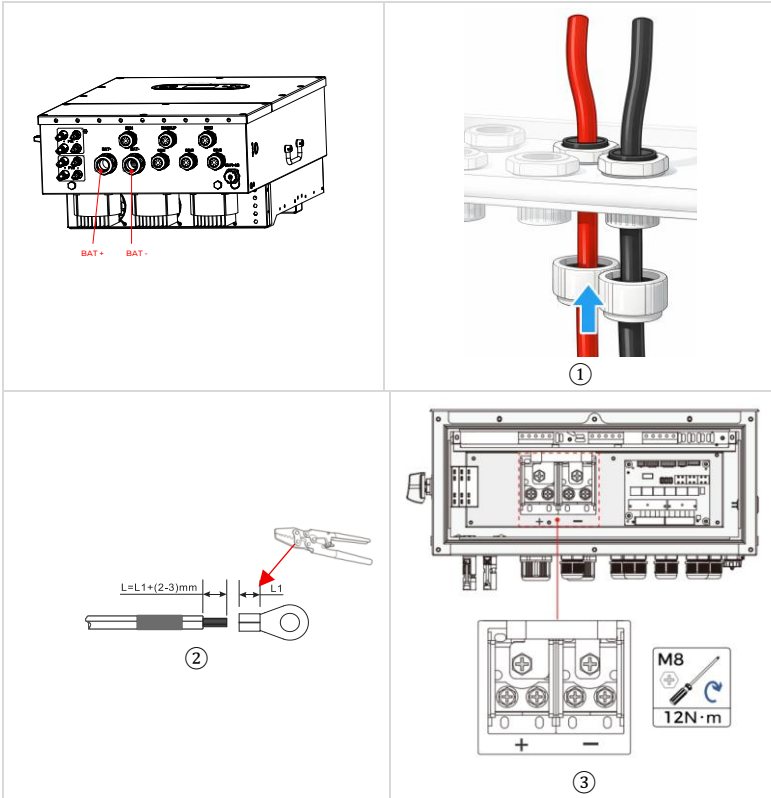

Figure 5-2(a) Install battery connection

- ▶ To ensure the safe operation of the inverter, it is necessary to carefully check that the positive and negative cables of the battery port cable, they cannot be reversed.

- ▶ It is recommended to add an external DC Switch for turning off batteries.

When the lead-acid battery is connected, its temperature sensor needs to be connected to the pin 1 and pin 2 of the COM3 port, so as to realize the real-time monitoring of lead-acid battery temperature. The actual wiring diagram is

shown in 5-2(b). Connect one end of the temperature sensor cable plug to the COM3 interface, and the sensor is placed on the surface of the lead-acid battery housing.

⚠ DANGER

- ▶ When using lead-acid batteries, a temperature sensor must be connected to prevent danger from excessive temperatures.

- ▶ The temperature sensor wiring has no polarity.

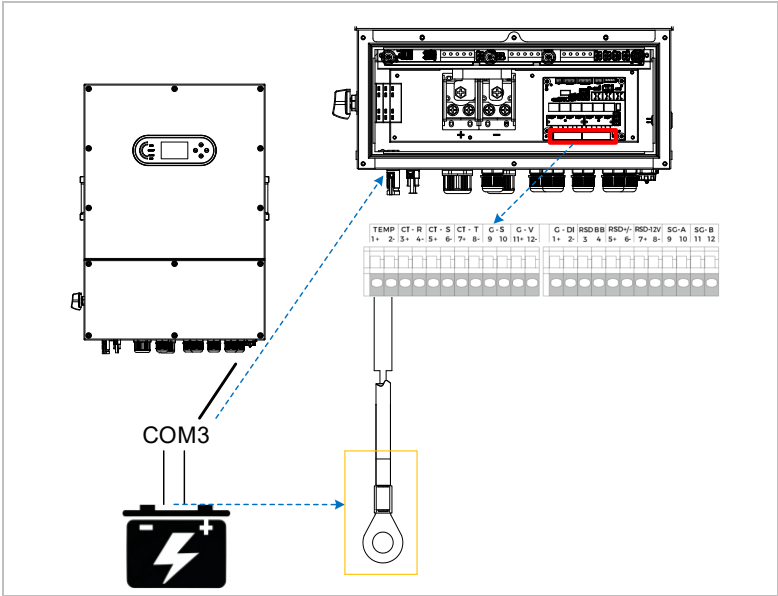

Figure 5-2(b) Temperature Sensor Connection for Lead-Acid Battery

5.4 PV Connection

Procedure:

Step 1 Select the appropriate cable type and specifications according to the Table 5-4. Remove cable glands from the positive and negative connectors. (It is recommended that the positive and negative be distinguished by different colors)

Table 5-4 Recommended PV cables for different models

Model	Cross-sectional area of cables
THY-T10K-LV	4.0~6.0mm ² (12AWG~10AWG)
THY-T12K-LV	
THY-T15K-LV	
THY-T20K-LV	

Step 2 Remove the insulation layer with an appropriate length from the positive and negative power cables by using a wire stripper as show in Figure 5-3①.

Step 3 Insert the stripped positive and negative power cables into the positive and negative metal terminals respectively and crimp them using a crimping tool. Ensure that the cables are crimped until they cannot be pulled out by force less than 400 N, as shown in Figure 5-3②.

Step 4 Insert crimped power cables into corresponding housings until you hear a "click" sound. The power cables snap into place, as shown in Figure 5-3③.

Step 5 Reinstall cable glands on positive and negative connectors and rotate them against the insulation covers, as shown in Figure 5-3④.

Step 6 Use the multi-meter, measure the PV port voltage Uoc, and then make the connection with the inverter to prevent live operation, as shown in Figure 5-3⑤

Step 7 Insert the positive and negative connectors into corresponding PV terminals of the inverter until you hear a "click" sound, as shown in Figure 5-3⑥⑦.

To remove the PV connector, you need to press the grooves on both sides of the terminal to apply force outward.

- ▶ The inverter has two MPPTs, which can operate independently or in parallel. The inverter can automatically identify the MPPT operating mode.

⚠ DANGER

- ▶ Before removing the positive and negative connectors, ensure that the DC switch is off.

- ▶ The system has PV anti-reverse connection function, which can protect the device from being damaged when the input is reversed. Therefore, to ensure the safe operation of the inverter, the PV positive and negative poles cannot be reversed, otherwise the inverter will report the PV reverse connection failure.
- ▶ If the PV input cable is reversed by mistake and the “DC switch” is set to “ON”, do not perform any operations on the positive or negative connectors of the DC switch and PV terminals immediately. Otherwise, the device may be damaged. You need to wait until the solar irradiance decreases at night. When the photovoltaic module current is reduced to below 0.5A, set the “DC switch” to "OFF", and remove the positive and negative connectors of the PV end to correct the polarity of the input line.

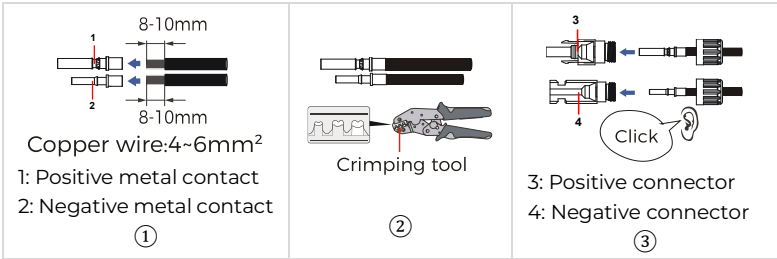

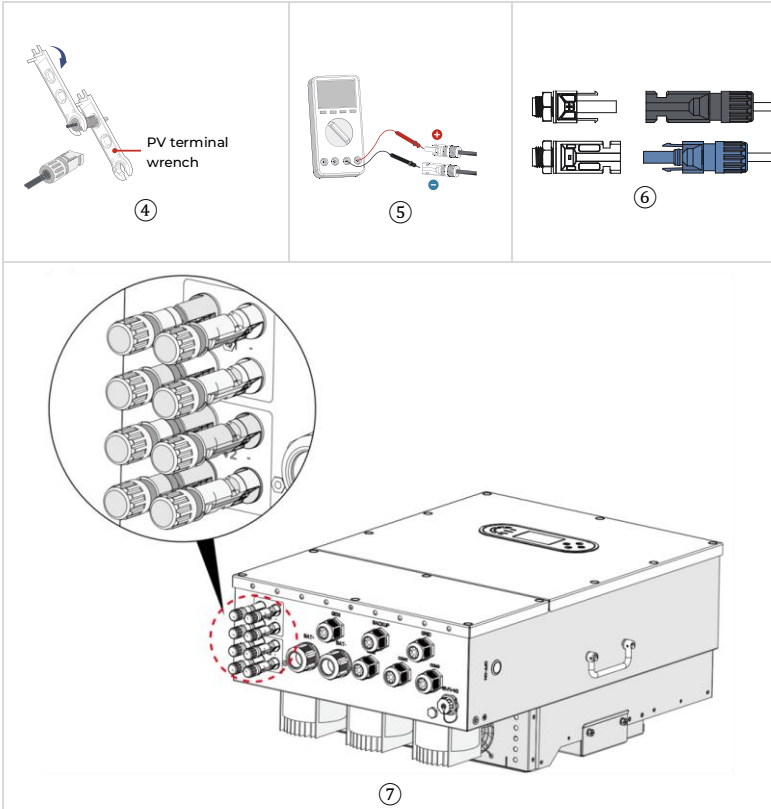

Figure 5-3 Connect PV

5.5 Load connection

Procedure:

Step 1 Select the appropriate cable type and specifications according to the Table 5-5.

Step 2 The prepared cable is inserted through the BACKUP port as shown in Figure 5-4①.

Step 3 Remove the insulation layer of the cable by using a wire stripper according to the Figure 5-4②.

Step 4 Insert the stripped power cables into the cord end terminals respectively and crimp them by using a crimping tool, as shown in Figure 5-4③.

Step 5 The cables shall be connected to the ports according to R, S, T, N, PE respectively as shown in Figure 5-4④.

Table 5-5 Recommended Load cables for different models

Model	Cross-sectional area of cables
THY-T10K-LV	10mm ² (7AWG)
THY-T12K-LV	
THY-T15K-LV	
THY-T20K-LV	

- Do not remove the BACKUP plug from the inverter when it is working.

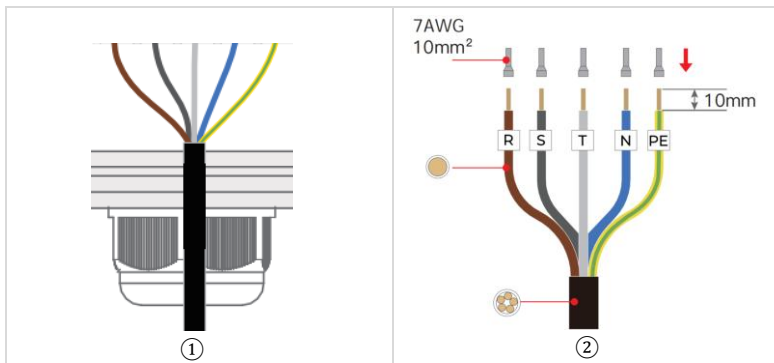

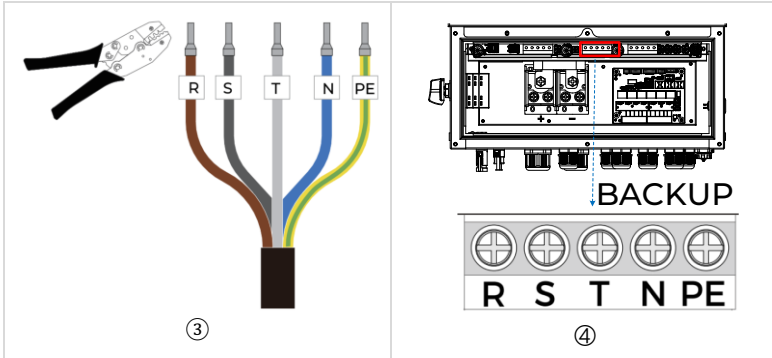

Figure 5-4 Backup connection

5.6 Grid connection

The inverter is equipped with an integrated residual current monitoring unit. When the inverter detects that the residual current exceeds limitation, the connection to the power grid will be quickly disconnected.

If the external ac switch has leakage protection function, its rated leakage action current is required to be $\geq 300\text{mA}$.

Procedure:

Step 1 Select the appropriate cable type and specifications according to the Table 5-6.

Step 2 The prepared cable is inserted through the GRID port as shown in Figure 5-5①.

Step 3 Remove the insulation layer of the cable by using a wire stripper according to the Figure 5-5②.

Step 4 Insert the stripped power cables into the cord end terminals respectively and crimp them by using a crimping tool, as shown in Figure 5-5 ③.

Step 5 The cables shall be connected to the ports according to R, S, T, N, PE respectively as shown in Figure 5-5④.

Table 5-6 Recommended Backup cables for different models

Model	Cross-sectional area of cables
THY-T10K-LV	16mm ² (5AWG)
THY-T12K-LV	
THY-T15K-LV	
THY-T20K-LV	

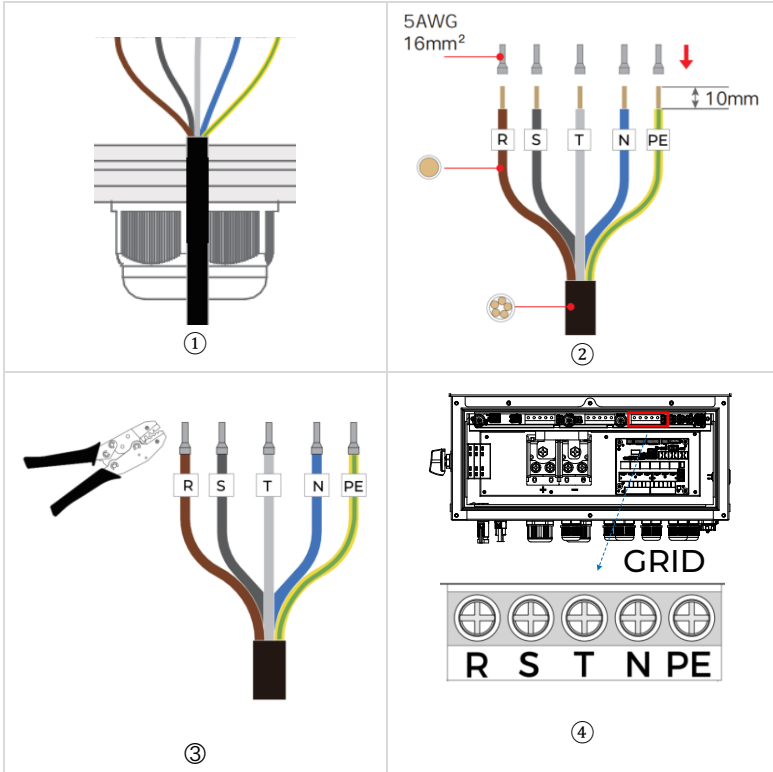

Figure 5-5 Grid connection

5.7 GEN connection

Step 1 Select the appropriate cable type and specifications according to the Table 5-5.

Step 2 The prepared cable is inserted through the GEN port as shown in Figure 5-6①.

Step 3 Remove the insulation layer of the cable by using a wire stripper according to the Figure 5-6②.

Step 4 Insert the stripped power cables into the cord end terminals respectively and crimp them by using a crimping tool, as shown in Figure 5-6③.

Step 5 The cables shall be connected to the ports according to R, S, T, N, PE respectively as shown in Figure 5-6④.

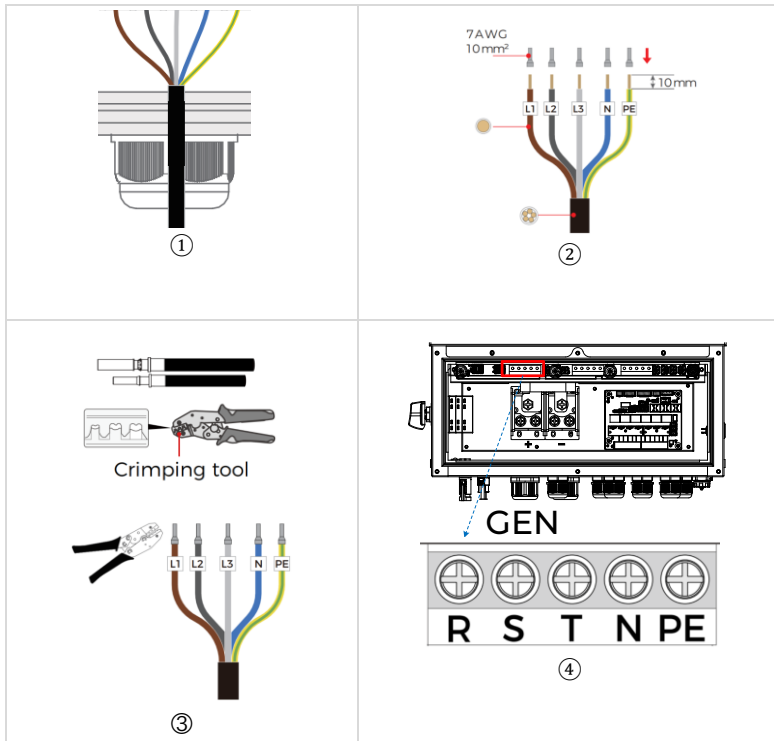

Figure 5-6 Generator connection

5.8 System electrical topology

The system electrical topology varies depending on the legal requirements of different countries and regions. For most countries and regions, please follow the electrical topology in Figure 5-7 (a). The back-up PE line and earthing bar must be grounded properly and effectively. Otherwise, the back-up function may be abnormal when the grid fails.

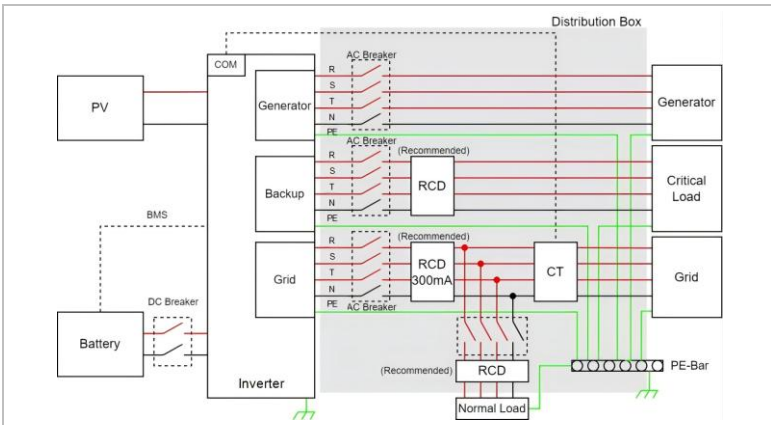

Figure 5-7(a) On-Grid system Electrical Topology
(N and PE wires are disconnected)

For Australia and New Zealand, please follow the electrical topology in Figure 5-7(b), where N and PE are connected in the distribution box.

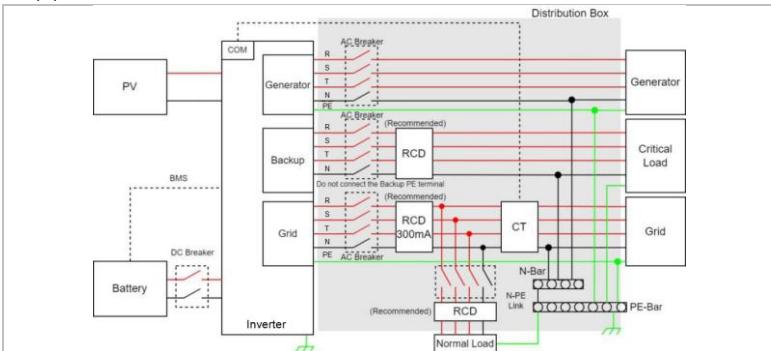

Figure 5-7(b) On-Grid system Electrical Topology
(N and PE wires are connected in the distribution box)

⚠ DANGER

- ▶ Install Residual current device (RCD) in front of the load
- ▶ RCD is necessary for critical load, but optional for normal load.
- ▶ In off-grid mode, the EPS port has no RCD protection, and load leakage may cause electric shock. To ensure protection, all load circuits must use Type B RCDs with a rated residual operating current not exceeding 30 mA.

- ▶ In the menu of the inverter, Neutral Point Grounding function is disabled in default state.

5.9 External communication interface

The external communication line is led out from the port below the inverter, as shown in Figure 5-8, and its terminal type is shown in Table 5-6.

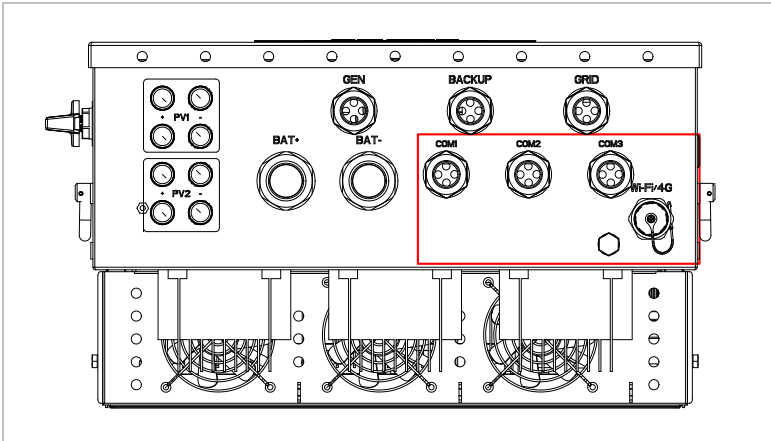

Figure 5-8 Communication port

Table 5-7 Communication line type

Port	Port Type	Description
COM1	4 holes watertight cable gland	Used for RJ45 connection inside wiring box
COM2	4 holes watertight cable gland	Used for RJ45 connection inside wiring box
COM3	4 holes watertight cable gland	Used for 12 PIN terminal block connection inside wiring box
Wi-Fi/4G	USB	Used for TUNCMATIK data logger or USB disk connection

Wiring steps for COM1-COM3:

Step 1 Loose the cable gland and remove the watertight caps inside the cable gland based on the number of the cables and keep the unused holes with watertight cap.

Step 2 Lead the cable into the holes in the cable gland.

Step 3 Connect the cable to the corresponding terminals inside the wiring box.

Step 4 Reassemble the cable gland and ensure there is no bending or stretching of the cables inside the wiring box

CAUTION

- ▶ The 4-hole fastening rings inside the cable gland for COM are with openings on the side.
- ▶ Please separate the gap with hand and squeeze the cables into the holes from the side openings

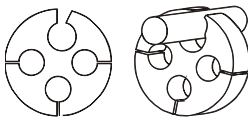

5.9.1 USB/WI-FI communication interface

Step 1 Remove the protective cover from the USB/Wi-Fi port of the inverter.

Step 2 Install the datalogger on the USB/Wi-Fi port.

Step 3 Tighten the connecting nut on the datalogger.

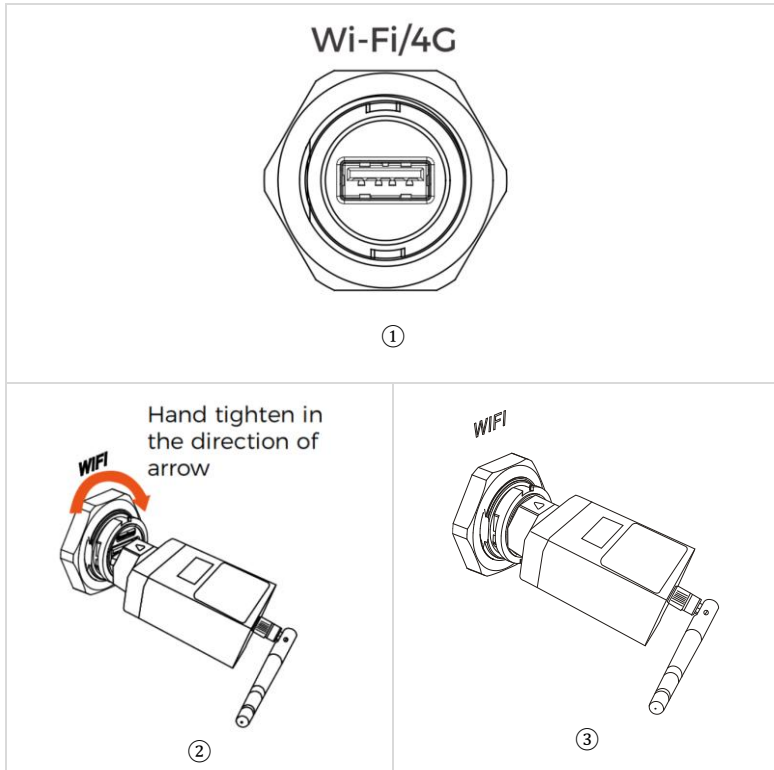

Figure 5-9 USB/Wi-Fi communication interface

Table 5-8 Interface description

PIN	Definition	Function	Note
1	GND.S	USB power -	The USB power supply is 5V/1A, it Cannot be used for external device charging
2	DP	USB data +	
3	DM	USB data -	
4	VBUS	USB power +	

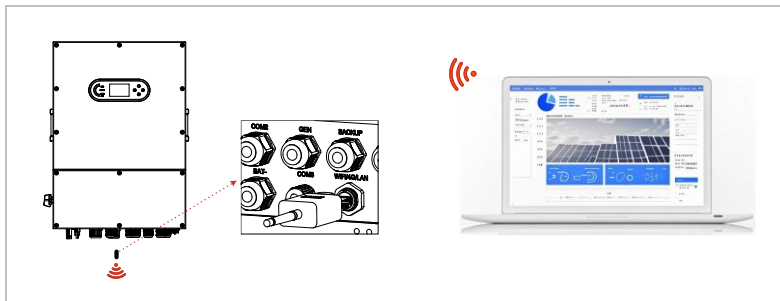

Figure 5-10(a) Collects information about single inverter

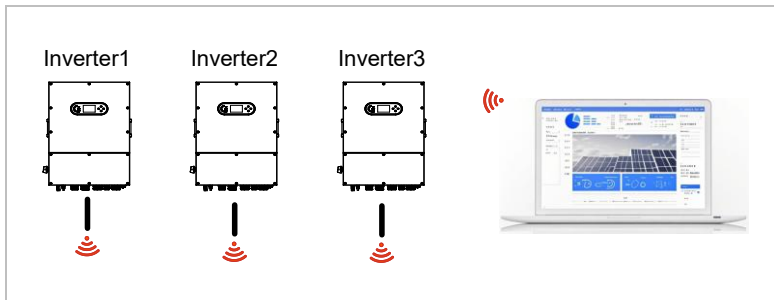

Figure 5-10(b) Collects information about single inverter

The operation information (generated energy, alert, operation status) of the inverter can be uploaded to the server via Wi-Fi/GPRS.

Users can choose to use web or APP for monitoring and viewing according to their needs. The collected information is shown in Figure 5-10. You need to

register an account and bind the device with the Wi-Fi/GPRS SN number. The SN number of the Wi-Fi/GPRS shall be affixed to the package box and the Wi-Fi/GPRS.

APP: Android: Go to Android Market and search “Solarviews”.

IOS: Go to App Store and search “Solarviews”.

Solarviews



5.9.2 COM-Multifunction communication interface

The internal communication of the inverter is shown in Figure 5-11, and its functional description is shown in Table 5-8.

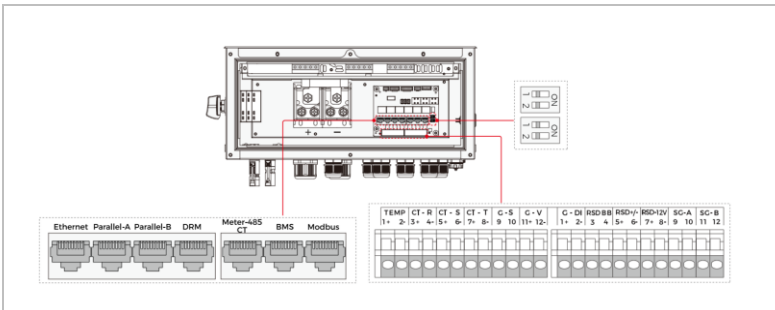

Figure 5-11 Internal communication ports overview

Table 5-8 Internal communication ports description

Terminal	Type	Description
Ethernet	RJ45	(Optional) Used for Modbus TCP communication with 3rd party external device or controller.
BMS	RJ45	Used for CAN communication between inverter and Lithium-ion battery BMS.
CT	RJ45	(Optional) Used for RS485 communication between inverter and the smart meter.
DRM	RJ45	(Optional) To realize Demand Response or Logic Interface function, this function may be required in UK and Australia.
Modbus	RJ45	(Optional) Used for Modbus RTU communication with 3rd party external device or controller.
Parallel-A	RJ45	(Optional) Parallel operation communication port.
Parallel-B	RJ45	(Optional) Parallel operation communication port
Switch SW1	-	A 120Ω termination resistor will connect to communication port when Switch SW1 is turned to ON position. Position 1 is for Modbus RTU communication, and position 2 is for Parallel operation communication.
Switch SW2	-	A 120Ω termination resistor will connect to communication port when Switch SW2 is turned to ON position. Position 1 is for BMS CAN communication, and position 2 is for Meter RS-485 communication.
TEMP	Terminal Block	Pin 1 and Pin 2 (From Left to Right) Used for Battery temperature sensor between inverter and lead-acid battery.
CT-R	Terminal Block	Pin 3 and Pin 4 (From Left to Right) are used for PCC-side Line-R CT wire connection.
CT-S	Terminal Block	Pin 5 and Pin 6 (From Left to Right) are used for PCC-side Line-S CT wire connection.
CT-T	Terminal Block	Pin 7 and Pin 8 (From Left to Right) are used for PCC-side Line-T CT wire connection.
G-S	Terminal Block	Pin 9 and Pin 10 (From Left to Right) Used for Generator start-stop signal.
G-V	Terminal Block	Pin 11 & Pin 12 (From Left to Right) Output wet/dry node.

Terminal	Type	Description
G-DI	Terminal Block	Pin 1 & Pin 2 (From Left to Right) Used for emergency stop signal.
RSD B-B RSD +/- RSD-12V	Terminal Block	Reserved (RSD)
SG-A SG-B		Reserved (Heat pump)

► **BMS Terminal Connection**

CAN communication is supported between inverter and compatible battery models.

Please lead the CAN cable through the COM1 or COM2 port of the inverter and connect to the BMS terminal with RJ45 connector.

Before connecting CAN cable with the battery, please check whether the communication pin sequence of the inverter and the battery match; If it does not match, you need to cut off the RJ45 connector at one end of the CAN cable and adjust the pin sequence according to the pin definitions of both inverter and battery.

Pin definition of the inverter BMS Port is following EIA/TIA 568B.

Table 5-9 Pin definition of BMS port

Pin	Wire color	Definition	Wiring diagram
1	Orange and White	\	
2	Orange	\	
3	Green and White	\	
4	Blue	CAN-H	
5	Blue and White	CAN-L	
6	Green	\	
7	Brown and White	\	
8	Brown	\	

► **Meter/CT Terminal Connection (Optional)**

If a smart meter is preferred to be installed other than the provided CT, please contact Tuncmatik sales rep to order the smart meter and corresponding meter CT.

Please lead the Meter RS485 cable through the COM1 or COM2 port of the inverter and connect to the Meter terminal with RJ45 connector.

Pin definition of the Meter and CT Terminal as follows:

Table 5-10 Pin definition of Meter/CT port

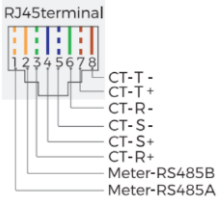
Pin	Wire color	Definition	Wiring diagram
1	Orange /White	Meter RS485A	
2	Orange	Meter RS485B	
3	Green /White	CT-R+	
4	Blue	CT-S+	
5	Blue and White	CT-S-	
6	Green	CT-R-	
7	Brown and White	CT-T+	
8	Brown	CT-T-	

The CT on the PCC side can also be connected to the 12-pin terminal, which are respectively connected to Pin3&Pin4, Pin5&Pin6, Pin7&Pin8.

► **Meter Connection**

The inverter supports connecting smart meter with CTs and direct-connected meter.

The smart meter with CTs is shown in the Figure 5-12(a)①, Pin1/2 of RJ45 terminal on the inverter correspond to Pin24/25 respectively on the meter, as shown in Figure 5-12(a)③.

The connection mode is shown in Figure 5-12(a)②. The Pin1/4/7/10 on the electricity meter are connected to voltage signals L and N respectively. And the current signals need to be connected through the current transformer, Pin31/33, Pin34/36, Pin37/39 correspond to the current transformer.

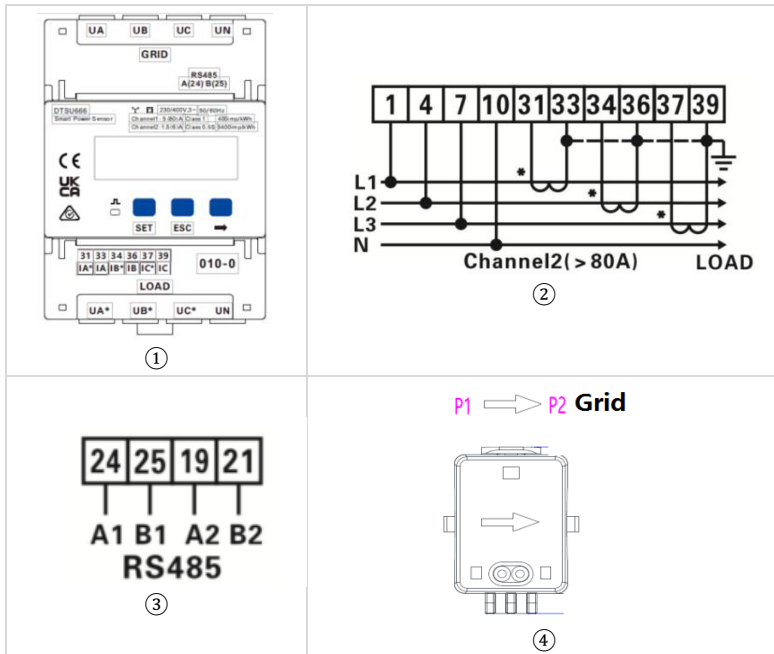

Figure 5-12(a) Meter (Instrument Transformer Meter)

ELECTRICAL CONNECTIONS

The direct-connected meter is shown in the Figure 5-12(b)①, Pin1 and Pin2 correspond to PIN 24/25 respectively on the Meter, as shown in Figure 5-12(b) ③.

The connection mode is shown in Figure 5-12(b)②. The Pin1/3, Pin4/6, Pin7/9, Pin10/12 on the electricity meter are connected to voltage signals L and N respectively.

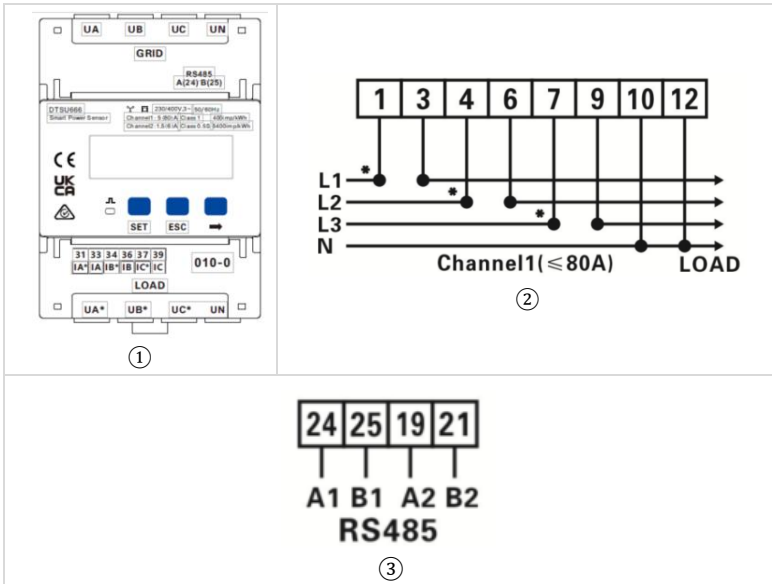

Figure 5-12(b) Meter (Direct-connected Meter)

► **CT Connection**

If you need to use the CT alone, attach the CT to Pin3/6, Pin4/5, Pin7/8 of the RJ45 terminal.

There are two ways to get grid current information:

Plan A: CT	Plan B: Meter +CT
CT (3000:1) 120A/40mA Pin3—Pin6: CT-R Pin4—Pin5: CT-S Pin7—Pin8: CT-T	Meter: DTSU666 DIN-RAIL METER + 120A/40mA CT

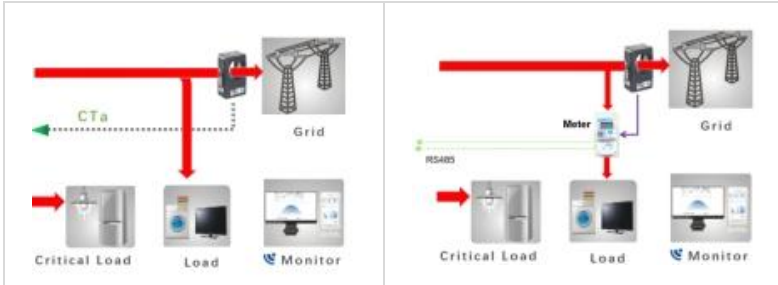

► **RS485 Port Connection (Optional)**

If a 3rd party external device or controller needs to communicate with the inverter, the RS485 port can be used. Modbus RTU protocol is supported by Tuncmatik inverters.

To acquire latest protocol document, please contact Tuncmatik local service team or Tuncmatik sales.

Pin definition of the RS485 port is following EIA/TIA 568B.

Table 5-11 Pin definition of RS485 port

Pin	Wire color	Definition	Wiring diagram
1	Orange and White	\	
2	Orange	\	
3	Green and White	\	
4	Blue	RS485B	
5	Blue and White	RS485A	
6	Green	\	
7	Brown and White	\	
8	Brown	\	

▶ **12-pin Communication Terminal Block**

Terminal Block Connection Steps:

Step 1 Lead the wires through the hole in COM3 port. (Hole Diameter: 2 mm).

Step 2 Strip the wires for 9mm length.

Step 3 Use slot type screwdriver to press the block on the top.

Step 4 Insert the exposed copper part of the cable into the terminal.

Step 5 Remove the screwdriver and the terminal will clamp down on the exposed copper part.

Step 6 Give the cable a gentle tug to ensure that it is firmly secured.

▶ **With Lead-acid Battery (Optional)**

When using lead-acid batteries, connect the battery temperature sensor to the 12-pin terminal block of the inverter for real-time temperature monitoring. Please contact Tuncmatik sales representative to order the battery temperature sensor.

Step 1 Take out the battery temperature sensor cable and lead through the COM3 port of the inverter and connect the positive and negative electrode lines to the Pin1 and Pin2 of the 12-pin terminal block.

Step 2 Fasten the temperature sensor ring onto the battery module. If no suitable fastening terminal can be found on the battery module, the sensor ring can be attached to the positive or negative pole of the battery module.

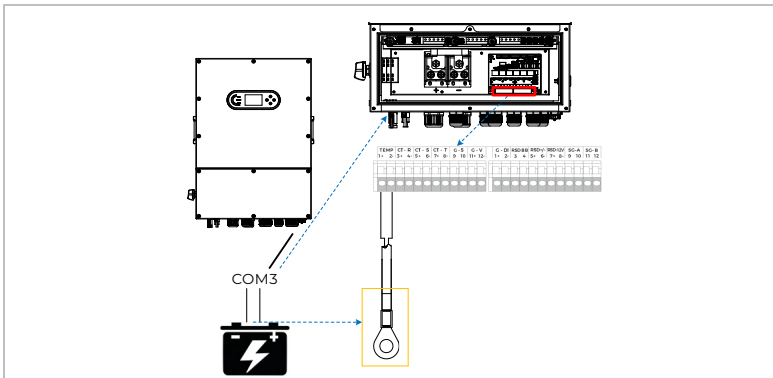

Figure 5-13 Temperature Sensor Connection for Lead-Acid Battery

- ▶ The temperature sensor wiring has no polarity.

▶ **CT Terminal Connection**

CT can not only share an RJ45 terminal with the Meter and be connected to the “Meter/CT Terminal”, but can also be directly connected to the 12-pin terminal of the inverter.

Step 1 Take out the CT cable and lead through the COM3 port of the inverter and connect the positive and negative electrode lines to the Pin3 and Pin4 of the 12-pin terminal block.

Step 2: Hang the CT near the grid side.

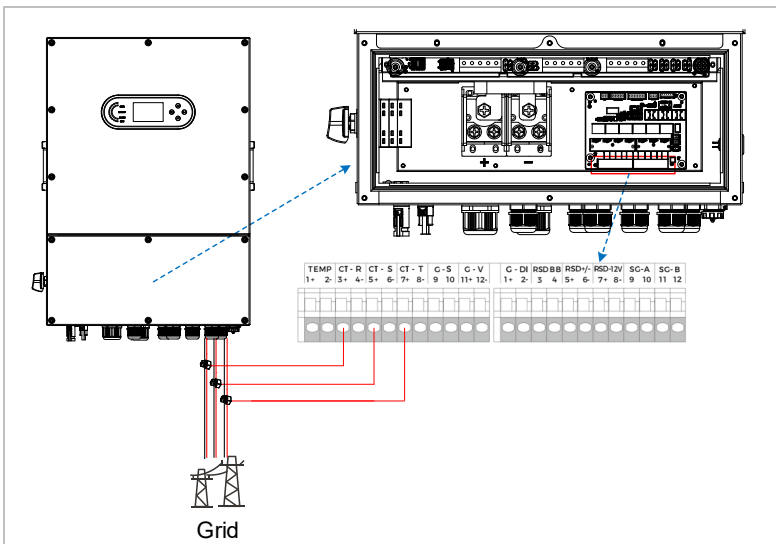

Figure 5-14 CT connected to 12-pin terminal block

► **G-S Terminal Connection**

The G-S terminal is a voltage-free dry contact signal for connecting with generator's NO relay to start up the generator when necessary.

When generator operation is not needed, Pin7 and Pin8 is in open circuit.

When generator operation is needed, Pin7 and Pin8 is in short circuit.

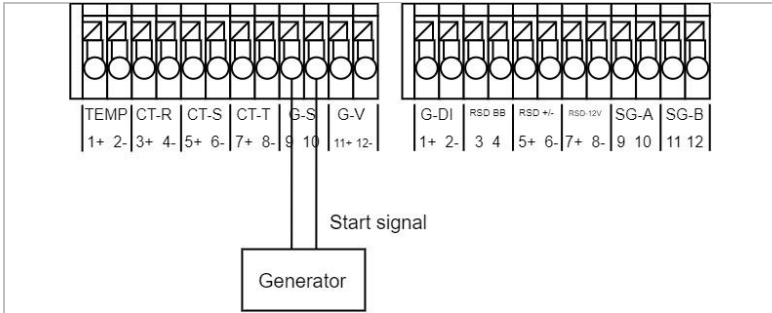

Figure 5-15 Generator start/stop signal wiring

► **G-DI Terminal Connection**

The G-DI terminal is a voltage-free dry contact signal for inverter to emergency stop when necessary.

When emergency stop is not needed, Pin1 and Pin2 is in open circuit.

When emergency stop is needed, Pin1 and Pin2 is in short circuit.

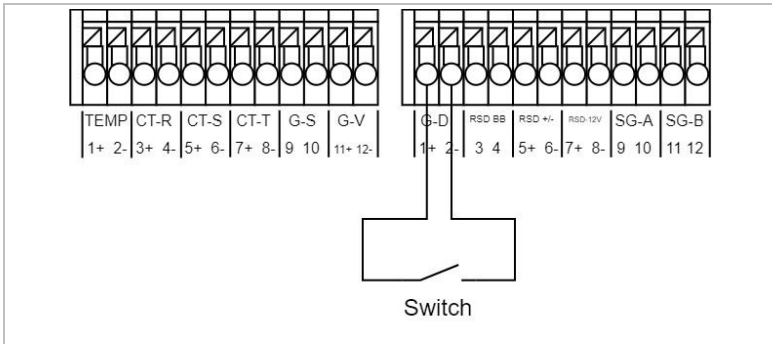

Figure 5-16 Inverter emergency stops signal wiring

5.9.3 Parallel communication interface

Up to 6 units of the inverter can be connected in parallel.

Please connect the paralleled inverters in daisy chain by using P-A and P-B terminals.

Standard CAT5 with shielding layers internet cable can be used.

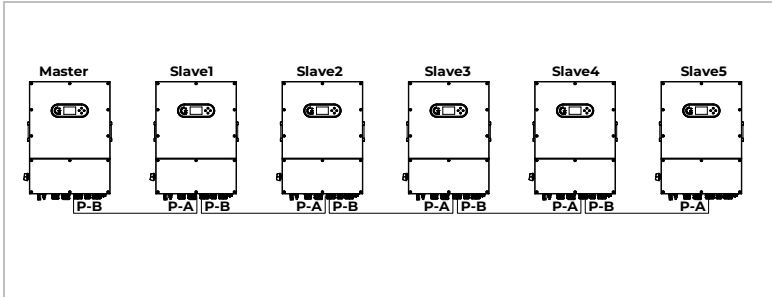
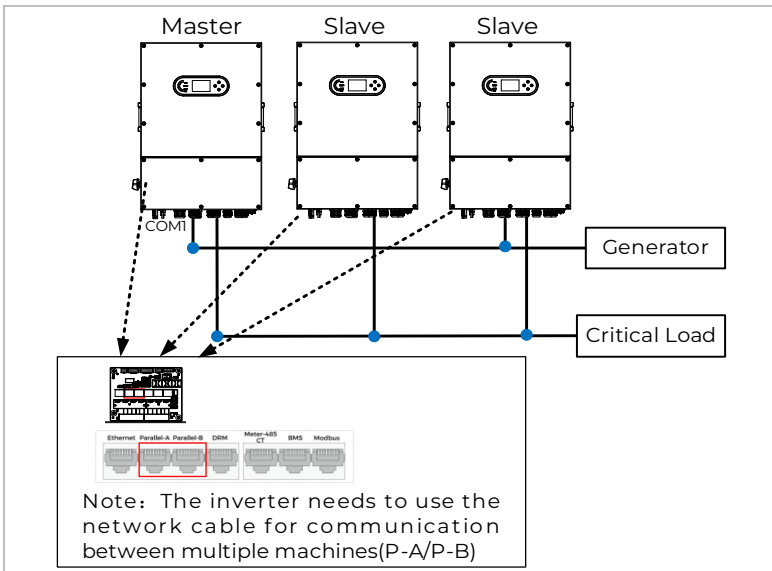
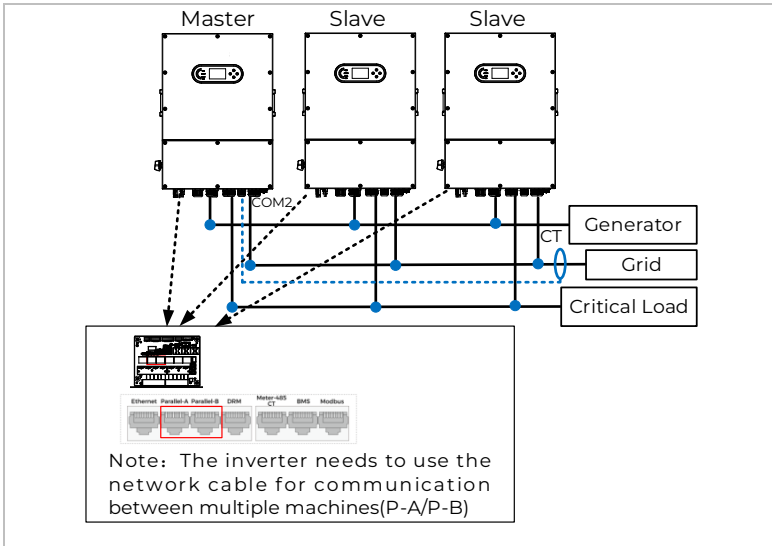

Figure 5-17 Parallel wiring diagram

- ▶ Both the first and the last inverter in parallel need to set the Switch SW1 position 2 to ON.

AC LOAD is also parallel for parallel machines:

1. Both the first and the last inverter in parallel need to set the Switch SW1 position 2 to ON.
2. The cable length of the AC LOAD terminal connected from the LOAD terminal to each machine shall be consistent with the specification of the cable length, so as to ensure that the loop impedance is consistent and the current of the LOAD current diverted to each machine is nearly equal.
3. When inverters in parallel, All AC grid should be Shared a total breaker; All AC LOAD should be Shared another total breaker.



5.10 Wiring Diagram Overview

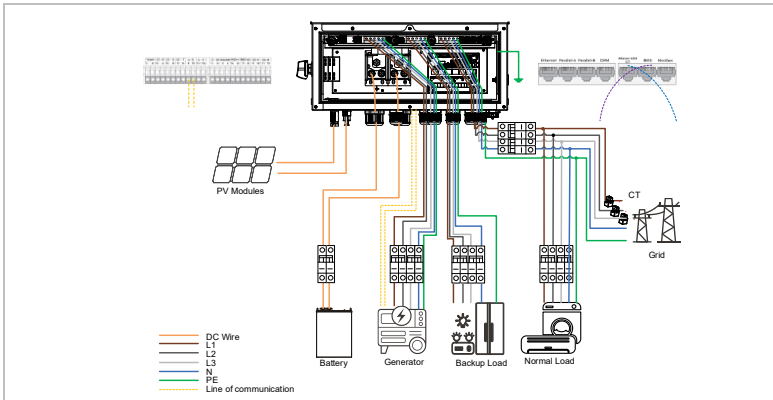

Figure 5-19(a) Overview of Wiring for Single inverter Systems

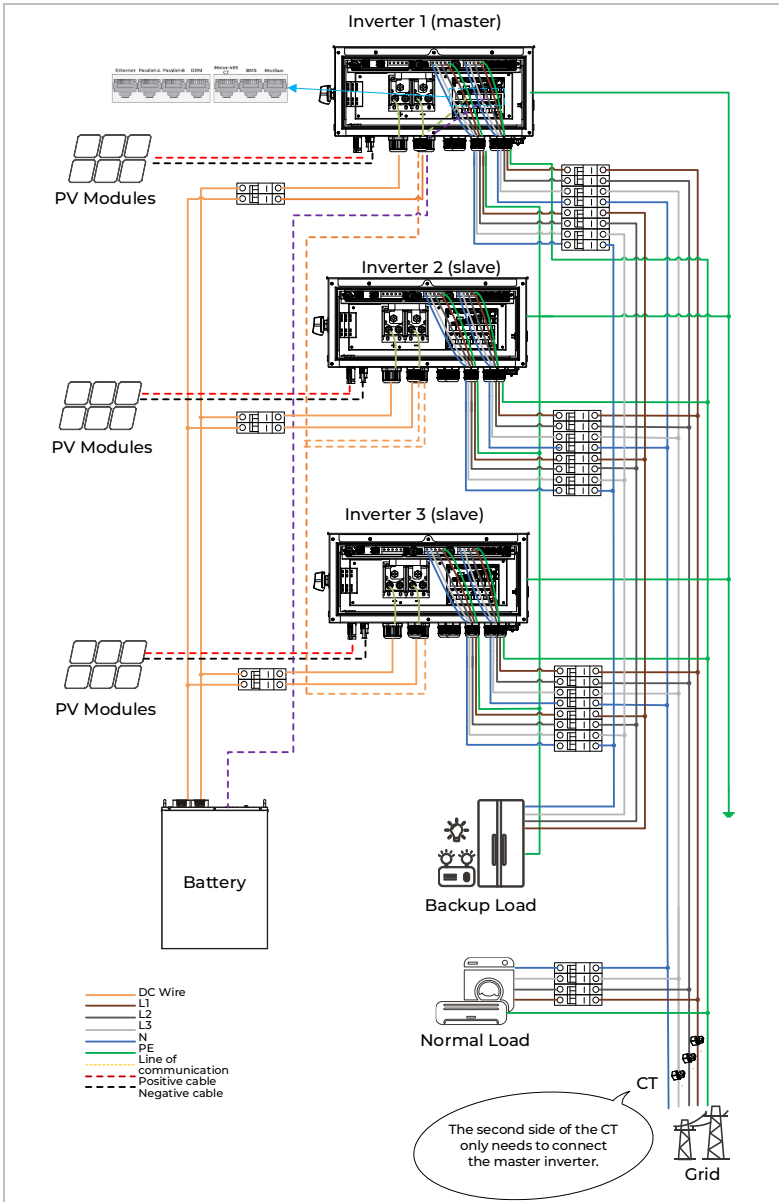

Figure 5-20(b) Overview of Multi inverter System Wiring

6 Buttons and indicator lights

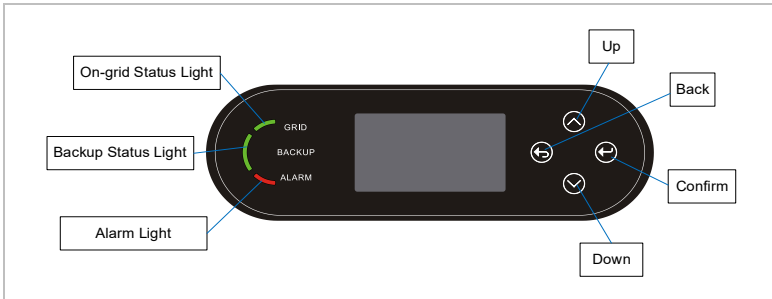

Figure 6-1 Buttons and indicator lights

6.1 Buttons

- ▶ Press “Back” to the previous screen or enter the main interface.
- ▶ Press “Up” to the upper menu option or value plus 1.
- ▶ Press “Down” to the lower menu option or value minus 1.
- ▶ Press “Confirm” to select the current menu option or switch to the next digit.

6.2 Indicator lights and status

Status	On Grid Green light	Off-Grid Green light	Alarm Red light
On-grid	ON	OFF	
Standby (On-Grid)	Flashing	OFF	
Off-Grid	OFF	ON	
Standby (Off-Grid)	OFF	Flashing	
Alarm			ON
Update	ON	ON	ON

There are three types of indicator lights: Grid, Backup and Alarm, display instructions are shown in the table above. Especially, Alarm light may turn on in any grid or standby status. \

7 Operation

7.1 Double Check

Please double check the following before operation.

1. Inverter is firmly fastened to the mounting bracket on the wall.
2. PV+/PV- wires are firmly connected, polarity and voltage are correct.
3. BAT+/BAT- wires are firmly connected, polarity and voltage are correct.
4. DC isolator is correctly connected between battery and inverter, DC isolator: OFF.
5. GRID / LOAD/GEN cables are firmly / correctly connected.
6. AC circuit breaker is correctly connected between inverter GRID port and GRID, circuit breaker: OFF.
7. AC circuit breaker is correctly connected between inverter LOAD port and critical load, circuit breaker: OFF.
8. For Lithium-ion battery, please ensure that the communication cable has been correctly connected.

7.2 First Time Setup (IMPORTANT!)

IMPORTANT: Please follow the following procedure to switch ON inverter. When switch off the inverter, simply follow the reverse sequence of operations.

1. Make sure the inverter is powered off.
2. Turn ON the DC circuit breaker between battery and inverter.
3. Activate the lithium-ion battery if you have one.
4. Turn on the PV switch on the inverter
5. Turn ON the AC circuit breaker between the inverter Backup port and critical load.
6. Turn ON the AC circuit breaker between the inverter GRID port and the power grid.
7. Press the DC button on the inverter.
8. Inverter should start to operate now.

You need to set the following parameters before inverter starts to operate.

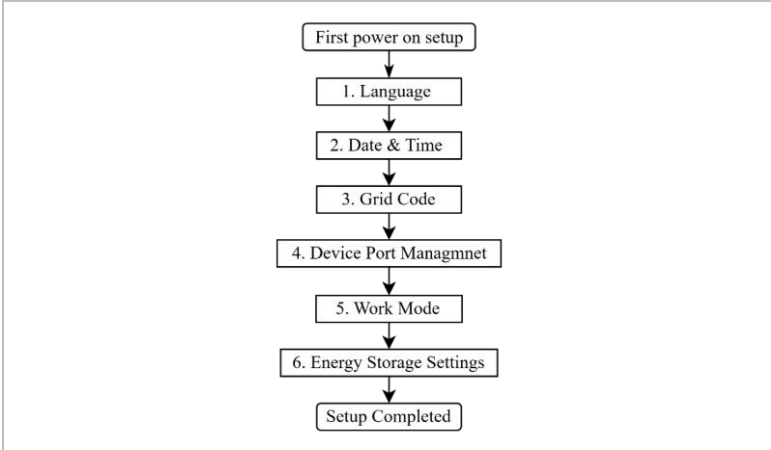

- Language:** Select the display language for LCD, the default is English.

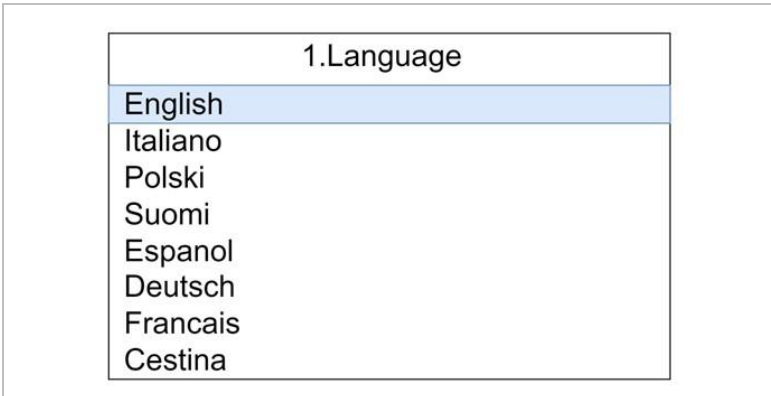

- Date & Time:** If you are connected to the host computer such as data collector or mobile phone APP, the time should have been calibrated to the local time.

2.Date & Time

Date: 2025 - 10 - 01

Time: 09: 00 : 00

3. **Grid Code:** Refer to the grid code table 7-1 below and select country and code.

3.Grid Code

020 Korea
021 Sweden
022 User-Def
024 Cyprus
025 India
026 Philippines
027 New Zealand
028 Brazil

➔

3.Grid Code

000 User def. -50Hz

Table 7-1 List of regulated countries

Code		Region	Grid Code	Description
000	000	Germany	VDE-AR-N 4105	Germany low-voltage
	005		VDE-AR-N 4110	VDE-AR-N 4110
	006		VDE-AR-N 4120	VDE-AR-N 4120
	007		VDE4105 cosPhiI	VDE4105 cosPhiI
	008		VDE4105 cosPhiP	VDE4105 cosPhiP
	009		VDE4105 Q-U	VDE4105 Q-U
001	000	Italy	CEI-021In.	Italy low-voltage ≤11kVA
	001		CEI-016	CEI-016
	002		CEI 0-21Ex.	Italy low-voltage >11kVA
	003		CEI 0-21 Areti	CEI 0-21 Areti
002	000	Australia	Australia-A	New South Wales, Victoria, Queensland.

Code		Region	Grid Code	Description
				south Australia, Australian Capital Territory, Jervis Bay Territory
	008		Australia-B	Western Australia , Northern Territory
	009		Australia-C	Tasmania
003	000	Spain	RD 1699	RD 1699
	002		NTS 631-BCD	Spain NTS typeB/C/D
	003		UNE 217002 RD647	Spain UNE+RD
	004		Spain island	Spain island
	006		NTS 631-A	Spain NTS typeA
004	000	Turkey	EN 50549-1	Turkey
005	000	Denmark	Denmark	Denmark
	001		DK-TR 322	DK-TR 322
	002		Western Denmark	Western Denmark
	003		Eastern Denmark	Eastern Denmark
006	000	Greece	GR-Continent	GR-Continent
	001		GR-Island	GR-Island
007	000	Netherland	EN 50549-1	Netherland low-voltage
008	000	Belgium	C10/11	Belgium
	002		Belgium-LV	Belgium-LV
009	000	UK	G99	UK output current >16A
	001		G98	UK output current≤16A
	002		G99/NI	Nor Ireland output current >16A
	003		G98/NI	Nor Ireland output current≤16A
010	000	China	NB/T 32004-B	NB/T 32004-B
	009		NB/T 32004-A	NB/T 32004-A
011	000	France	France	France
	001		FRArrete23	FRArrete23

Code		Region	Grid Code	Description
	003		France VFR 2019	France VFR 2019
	004		VDE 0126 Enedis	VDE 0126 Enedis
	006		VFR 2019 Enedis	VFR 2019 Enedis
	007		EN 50549-1	EN 50549-1
012	000	Poland	Poland-A	Poland-A:≤0.2MW
	004		Poland-ABCD	Poland-ABCD
013	000	Austria	TOR Erz. cosPhi1	TOR Erz. cosPhi1
	001		TOR Erzeuger Q-UFrance VFR	TOR Erzeuger Q-UFrance VFR
015	000	Switzerland	NA/EEA NE7-A	Switzerland-A
018	001	EU	EN 50549-1	EN 50549-1 230V 50Hz
	003		EN 50549-2	EN 50549-2
019	000	IEC 61727	IEC 61727	IEC61727 230V 50Hz
020	000	Korea	Korea	Korea
021	000	Sweden	Sweden	Sweden
	001		EIFS 2018:2-A	Sweden typeA
022	000	User -Def.	User def.-50Hz	User defined-50 Hz
024	000	Cyprus	Cyprus	Cyprus
	001		CY-LV-RES	CY-LV-RES
	002		CY-LN/MV-COM	CY-LN/MV-COM
	003		CY-LV/MV-UT	CY-LV/MV-UT
025	000	India	IEC 61727-India	IEC 61727-India
027	000	New Zealand	New Zealand	New Zealand
029	000	Slovakia	SK-VSD	SK-VSD
	001		SK-SSE	SK-SSE
	002		SK-ZSD	SK-ZSD
030	004	Czech	PPDS A1/A2 2025	PPDS A1/A2 2025
031	000	Slovenia	SIST EN 50549-1	Slovenia
033	000	Ukraine	Ukraine	Ukraine
034	001	Norway	Norway-LV	Norway-LV
039	000	Ireland	EN 50549-1 Mini	EN 50549-1 Mini

Code		Region	Grid Code	Description
	001		EN 50549-1 Micro	single phase inverter≤6KVA; three phase inverter ≤11KVA
040	000	Thailand	Thai-PEA	Thai-PEA
	001		Thai-MEA	Thai-MEA
	002		Thai-PEA	Thai-PEA
044	000	South Africa	NRS 097-2-1	South Africa-A
046	000	Dubai	DEWG	DEWG
	001		DEWG-MV	DEWG-MV
111	000	Columbia	Columbia	Columbia
121	000	Saudi Arabia	Saudi Arabia	Saudi Arabia
122	000	Latvia	Latvia	Latvia
123	000	Romania	ANRE Nr.208	Romania
125	000	Finland	Finland	Finland
126	000	Hungary	Hungary	Hungary

 **CAUTION**

- ▶ It's very important to make sure that you have selected the correct country code according to requirements of local authority.
- ▶ Please consult qualified electrical engineer or personnel from electrical safety authorities about this.
- ▶ Tuncmatik is not responsible for any consequences arising out of incorrect country code selection.

4. **Device Port Management:** Managing PV, BAT, GRID, BACKUP and GEN external ports, LCD will display a corresponding preview interface based on port settings. The selections of each port refer to table below. When GRID port is GEN, generator icon will replace grid icon, then GEN port cannot be set as GEN.

Table 7-2 List of regulated countries

Port Name	Selection
PV	Enable/Disable
BAT	Enable/Disable
GRID	GRID/GEN/Disable
BACKUP	Enable
GEN	GEN/Smart Load/Disable

After confirming the ports setting, it will enter the detailed settings of each enabled port, such as PV input channel enable or disable.

Completed port icons turn black. The currently configured port icon blinks at 0.5-second intervals. Unconfigured port icons remain blank. Some ports may have multiple configuration interfaces.

Please refer to Device Port Management in **7.3.5 System Settings** for more details.

PV
BAT
GRID
Bckup

PV1: PV

PV2: PV

PV
BAT
GRID
Bckup

Battery Type 1/2

1. Lead Acid
2. PYLON
3. GENERAL
4. GTX5000S
5. SF-5KWH-L1
6. SF-16KWH-L1
7. LG

PV
BAT
GRID
Bckup

Battery Type 2/2

- 8.Alpha. ESS
- 9.CATL
- 10.WECO
- 11.Fronus
- 12.Dowell
- 13.Dyness

PV	BAT	GRID	Bckup	GEN
PCC Meter/CT Enable				

PV	BAT	GRID	Bckup	GEN
PCC Import Limit Control Enable				
PCC Import Limit Power 0001.5 kW				

PV	BAT	GRID	Bckup	GEN
Feed-in Limit Control Enable				
Feed-in Limit Power 0001.5 kW				

PV	BAT	GRID	Bckup	GEN
Backup Load Enable				

PV	BAT	GRID	Bckup	GEN
Control Mode Manual				
Rated Power 0005.0 kVA				

PV	BAT	GRID	Bckup	SmtLd
Mode Smart Mode				
Rated Power 0003.0kW				
Start SOC 080 %				
Stop SOC 010 %				

5. **Work Mode:** Select the working mode for inverter. The passive mode requires external remote EMS device to control power precisely; the others can run automatically. Please refer to **7.3.8 Work Mode** for details.

5.Work Mode
1.Self-use
2.Feed-in Priority
3.Peak Shaving
4.Time-of-use
5.Passive

6. **Energy Storage Settings:** Set Charge Limit SOC, On-grid Discharge Limit SOC, Off-grid Discharge Limit SOC and Off-grid Recovery Discharge SOC. When inverter is in on-grid state and enable the BACKUP port, the battery will discharge until it reaches the on-grid Discharge Limit SOC.

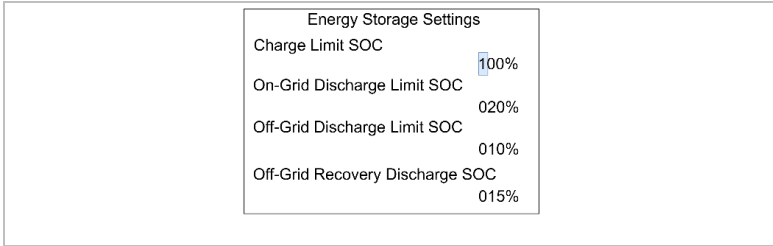

After completing first power on setup, LCD displays prompt interface **Success** for a second and enters to the homepage which shows Energy Flow Diagram.

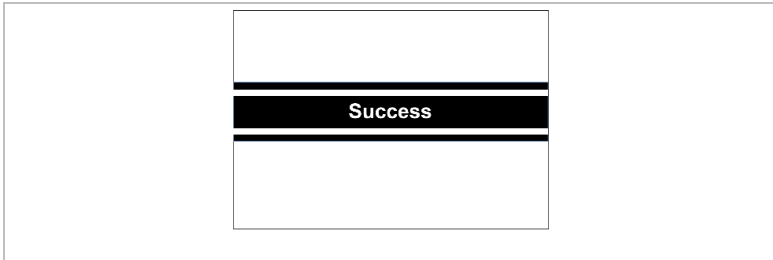

There are some other default parameters refer to the table below.

Table 7-3 List of regulated countries

Settings	Default Values
IV Curve Scan	Disable
Logic interface	Disable
Parallel Setting	Disable
Unbalanced Support	Disable
BACKUP GFCI	Disable
Neutral Point Grounding	Enable
E-STOP	Disable

7.3 Menu

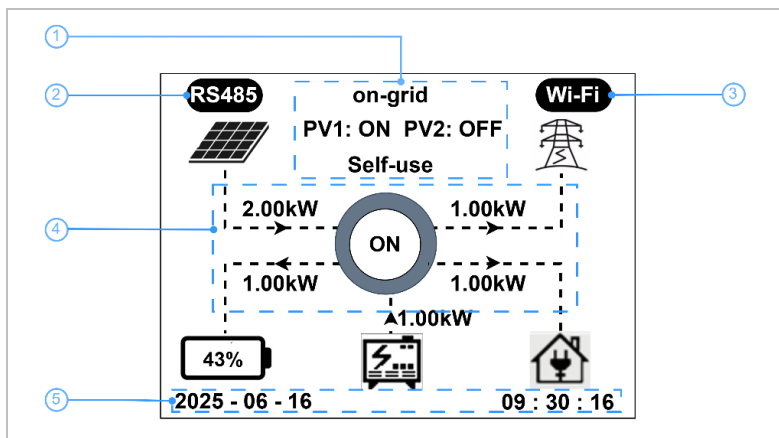

Figure 7-1 Homepage

- ▶ When the battery-side button is pressed, the circle in the center of the screen displays ON, otherwise, it shows OFF.



① Status Display: The status bar contains three rows. The first row displays the working status of the inverter, the second row displays the status of 4 external components, which automatically switch every 3 seconds, and the third row displays the working mode.

Table 7-4 Status



Operating Status	On-Grid	
	Off-Grid	
	Fault	
	Detecting	
	Standby	
Components Status	PV1	On/Off
	PV2	On/Off
	BAT	Charging/Discharging
	DRM	DRM0~DRM8
Working Mode	Self-use	
	Feed-in Priority	

	Peak Shaving
	Time-of-use
	Passive

②**External EMS & Master/Slave:** When an RS485 communication cable is externally connected to the inverter, the top-left corner of the screen will display .

When the inverter is configured as Master or Slave in Parallel settings, the top-left corner of the screen will display  or . The default is Master. The External EMS and the Master/Slave automatically switch every 3 seconds.





③**External Accessories:** When a meter is connected to the inverter, the top-right corner of the screen will display .



When a data logger or USB flash drive is connected to the inverter, the top-right corner of the screen will display  or .

The Meter icon and the data logger/ USB icon switch every 3 seconds

④**Energy Flow Diagram:** All icons in the diagram will be displayed dynamically based on port configuration. For example, if the GRID port is configured as GEN, the generator icon will replace the grid icon in the upper-right corner. Please refer to Device Port Management in the **7.3.5 System Settings**.

Table 7-5 Icons in Energy Flow Diagram

Symbol	Description	Notes
	PV	
	Battery	arrow pointing to battery = charging power; arrow pointing away from battery = discharging power
	Grid	arrow pointing to grid = feeding into grid; arrow pointing away from grid = drawing power from grid
	Generator	

Symbol	Description	Notes
	Household load	
	Smart load	

⑤ **System Time:** system time at this moment.

In homepage, press “back” button to enter main menu. Which has the following 7 options.

<p>Main Menu</p> <ol style="list-style-type: none"> 1. System Information 2. Real-time Information 3. Event List 4. Energy Statistic 5. System Settings 6. Advanced Settings 7. Firmware Update
--

7.3.1 System Information

1. System Information	----Press “Confirm”	
2. Real-time Information	Inverter (1)	Serial Number
3. Event List		Rated Power
4. Energy Statistics		Firmware Version
5. System Settings		Grid Code
6. Advanced Settings	Inverter (2)	BAT Channel
7. Software Upgrade		PV Channel 1
		PV Channel 2
	Inverter (3)	Work Mode

	RS485 Address
	BACKUP
	IV Curve Scan
Inverter (4)	Logic Interface
	Power Factor
	Feed-in Limit
	Insulation Resistance
Inverter (5)	Parallel
	Automatic Battery Active
	Unbalanced Support
Battery (1) (Acid)	Battery Capacity
	Max Charge Current
	Max Discharge Current
Battery (2) (Acid)	Max Charge Voltage
	Min Discharge Voltage
	Float Charge Voltage
	TEMPCO
Battery (3) (Acid)	Discharge Recovery Voltage
Battery (1~8) (Lithium-ion)	Serial Number
	Firmware Version
Battery (9) (Lithium-ion)	Max Charge Current
	Max Discharge Current
Battery (10) (Lithium-ion)	Charge Limit SOC
	On-grid Discharge Limit SOC
	Off-grid Discharge Limit SOC
	Off-grid Recovery Discharge SOC

- ▶ There are two sub information interfaces, Inverter and Battery.
- ▶ Battery interfaces display based on the battery type, acid or Lithium-ion. Particularly, Battery shows up to 16 serial numbers and firmware versions of Lithium-ion batteries connect to inverter, 2 batteries in every page. if the number is less than 16, the excess interface will be hidden automatically.
- ▶ Battery interface will show “No battery” if there is no battery connects to the inverter.

7.3.2 Real-time Information

When selecting bar is on Real-time Information, press “confirm” button, it will show 7 options in sub interface.

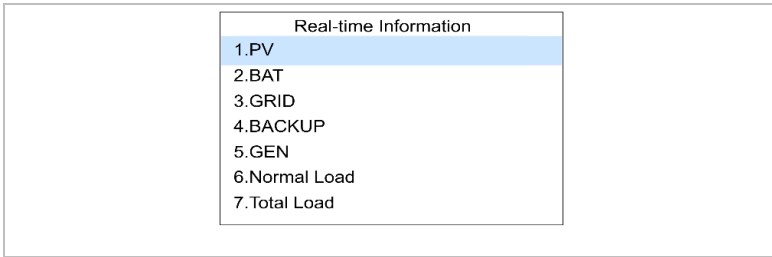

1. **PV:** It shows info of 2 PV input channels. External PV Power is the total PV power.

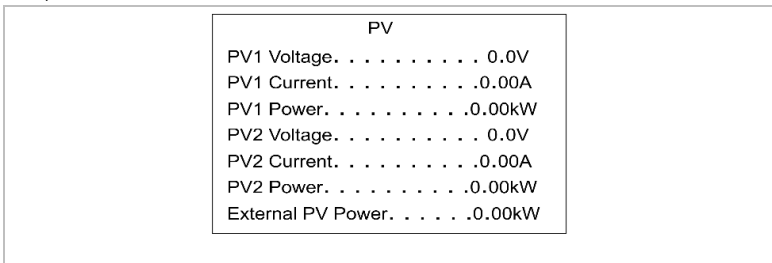

2. **BAT:** If BAT port connects no battery, it will only display BAT Port Info. On the contrary, it will display up to 8 pages of BAT Real Info if batteries are connected.

BAT Port Info	BAT1 Real Info
Voltage. 0.0V	Voltage. 0.0V
Current. 0.00A	Current. 0.00A
Power. 0.00kW	SOC. 100%
SOC. 100%	Max Cell Temp. 26.0°C
	Min Cell Temp. 26.0°C

3. **GRID:** Three phase GRID port information.

Grid
Voltage R.....230.0V
Voltage S.....230.0V
Voltage T.....230.0V
Power R.....6.6kW
Power S.....6.6kW
Power T.....6.6kW
Frequency.....50.00Hz

4. **BACKUP:** Information of BACKUP.

BACKUP
Voltage R.....230.0V
Voltage S.....230.0V
Voltage T.....230.0V
Power R.....6.6kW
Power S.....6.6kW
Power T.....6.6kW
Frequency.....50.00Hz

5. **GEN:** Information of generator.

GEN	
Voltage R	230.0V
Voltage S	230.0V
Voltage T	230.0V
Power R	6.6kW
Power S	6.6kW
Power T	6.6kW
Frequency	50.00Hz

6. **Normal Load:** Only power information.

Normal Load	
Power	.0.00kW

7. **Total Load:** Only power information.

Total Load	
Power	.0.00kW

7.3.3 Event List

There are two different kinds of lists, current and history.

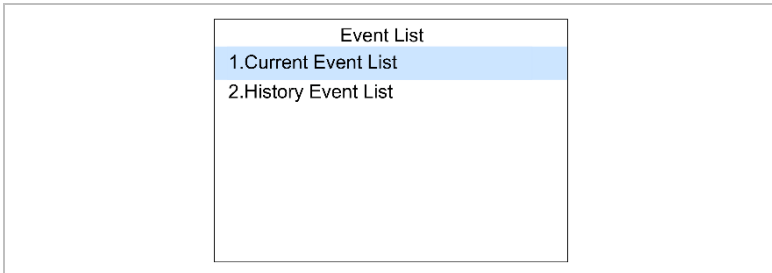

1. **Current Event List:** It shows all the events are happening right now. After one event recovers, current list will automatically clear it.
2. **History Event List:** It displays the last 100 historical events. Up and down button will switch the pages of event list, which show up to 8 events in a page. Press the confirm button once will switch between event description and trigger time.

7.3.4 Energy Statistic

This interface displays PV power consumption, load power consumption, grid sales, grid purchases, battery charging and discharging, represented by PV, Load, Import, Export, Charge and Discharge respectively.

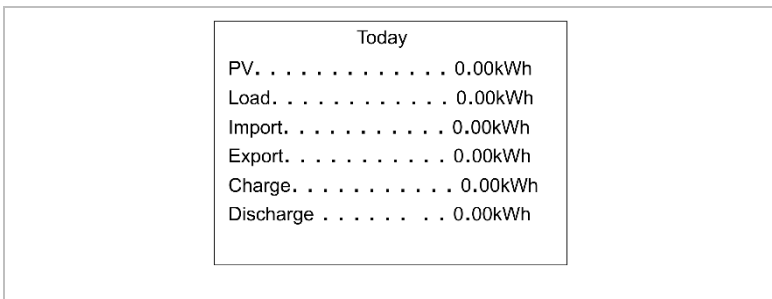

Press up and down button to switch between today, month, year and lifetime energy statistics interface.

7.3.5 System Settings

There are 7 setting options in System Settings interface.

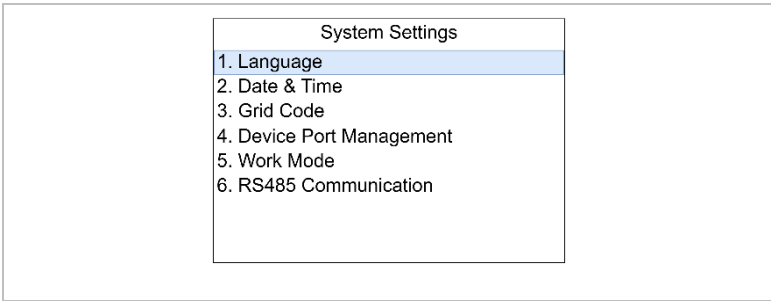

1. Language

Used to set the menu display language, the function is same as the language setting in procedure of first-time setup.

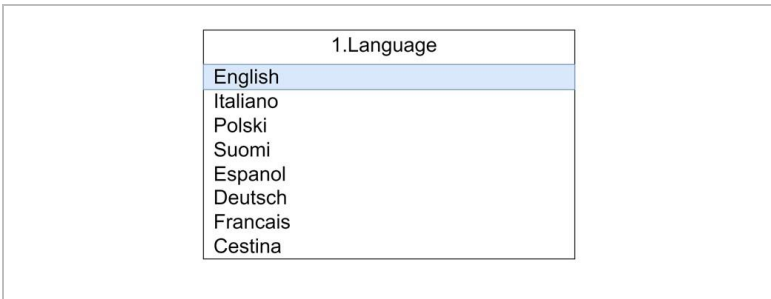

2. Date & Time

Set the system time for the inverter, the function is same as the time setting in procedure of first-time setup.

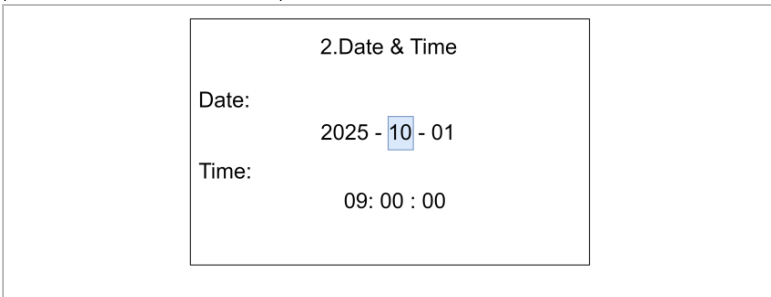

3. Grid Code

If user never input level 2 password, or entering the password and the screen turning off for 10 minutes, it is necessary to enter the password. Incorrect prompt will show up if the password doesn't match.

For the level 2 password, please consult the representative of TUNCMATIK.

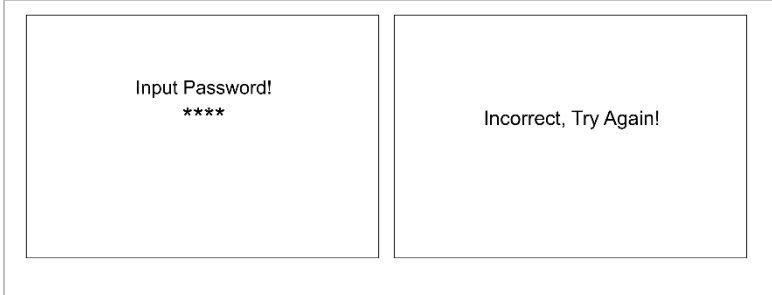

After inputting the right level 2 password, you can select the country and switch to different grid code, it is as same function as Grid Code setting in the procedure of first-time setup.

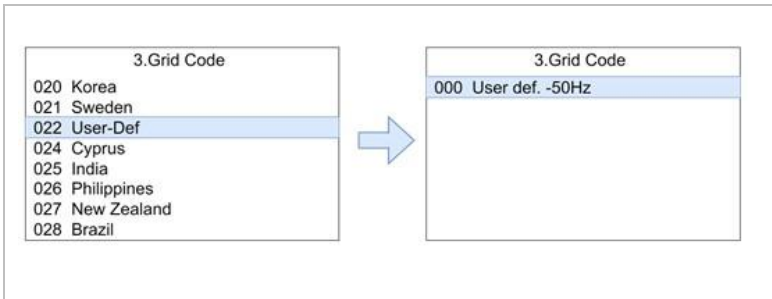

CAUTION

- ▶ It's very important to make sure that you have selected the correct country code according to requirements of local authority.
- ▶ Please consult qualified electrical engineer or the personnel from electrical safety authorities about this.
- ▶ Tuncmatik is not responsible for any consequences arising out of incorrect country code selection.

4. Device Port Management

There are 5 ports to set. Each port may affect Energy Flow Diagram in the homepage.

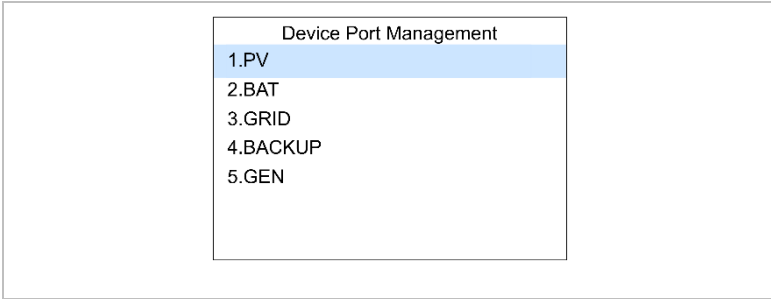

1. PV: Set the enable and disable of two PV channels, "PV" represents as enable. Even both channels are disabled, PV icon still exists in the Energy Flow Diagram.

2. BAT: User can enable or disable BAT port, which affects the battery icon in the Energy Flow Diagram, enable for showing the icon, disable for hiding it.

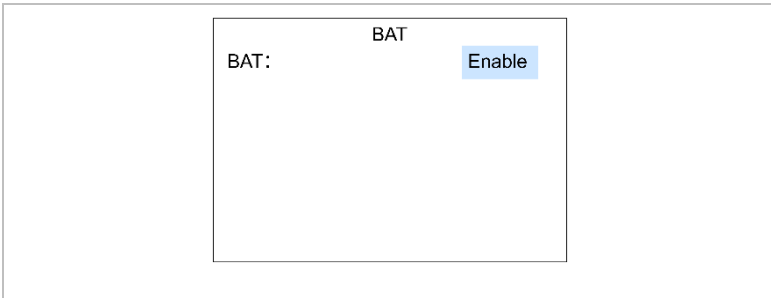

After press confirm button to enable port, LCD will display 2 pages, totaling 13 battery types for option. Lead Acid is the only lead acid battery, the rest are all Lithium-ion batteries.

Battery Type	1/2	Battery Type	2/2
1. Lead Acid		9. CATL	
2. PYLON		10. WECO	
3. GENERAL		11. Fronus	
4. GTX5000S		12. Dowell	
5. SF-5KWH-L1		13. Dyness	
6. SF-16KWH-L1			
7. LG			
8. Alpha. ESS			

Selecting Lead-acid will require additional settings for cell type and parameters. There are four cell types available.

Battery	Battery Cell Type	1/1
1. Battery Cell Type	1. Custom	
2. Battery Parameter	2. AGM	
	3. GEL	
	4. FLOODED	

If user select custom cell type, Battery Parameter will show 4 pages of settings.

Battery Parameter	1/4	Battery Parameter	2/4
Battery Capacity:	0020Ah	Max Charge Voltage:	57.0V
		Min Discharge Voltage:	46.0V
		Float Charge Voltage:	55.3V

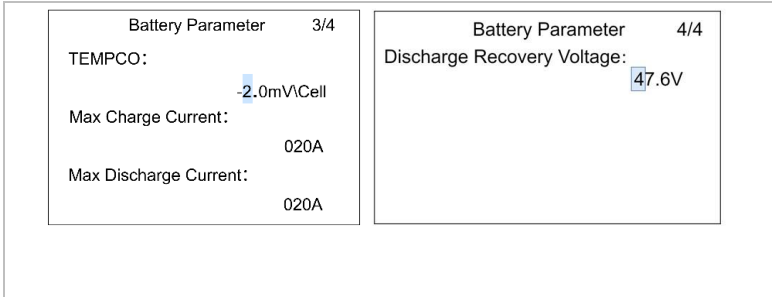

If user select non-custom cell type, such as AGM cell, Battery Parameter will show 2 pages of settings.

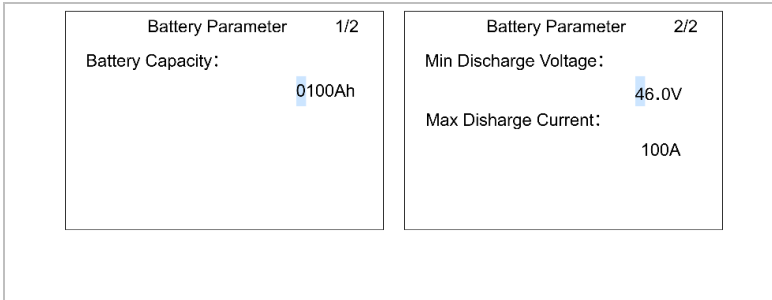

► If there is no battery connects to inverter effectively, even BAT port is enabled, Energy Flow Diagram will not show BAT icon.

3. GRID: There are 3 options for this port, Disable, GRID or GEN. Generator icon will replace grid icon in the upper right corner of Energy Flow Diagram when port is set as GEN, while other selections remain gird icon.

LCD will show the generator parameter settings when port set as GEN, generator has 2 control modes, Auto or Manual. Auto mode is controlled by SOC when BAT port set the Lithium-ion battery, while it runs by battery voltage when lead acid battery connects to machine.

GRID	
GRID:	GEN
Genset Mode:	<input type="button" value="Manual"/>
Rated Power:	0005.0kVA

<table border="1" style="width: 100%; border-collapse: collapse;"> <tr> <td colspan="2" style="text-align: center; padding: 5px;">GRID</td> </tr> <tr> <td style="padding: 5px;">GRID:</td> <td style="text-align: right; padding: 5px;">GEN</td> </tr> <tr> <td style="padding: 5px;">Genset Mode:</td> <td style="text-align: right; padding: 5px;"><input type="button" value="Auto"/></td> </tr> <tr> <td style="padding: 5px;">Start SOC:</td> <td style="text-align: right; padding: 5px;">40%</td> </tr> <tr> <td style="padding: 5px;">Stop SOC:</td> <td style="text-align: right; padding: 5px;">80%</td> </tr> <tr> <td style="padding: 5px;">Rated Power:</td> <td style="text-align: right; padding: 5px;">0005.0kVA</td> </tr> </table>	GRID		GRID:	GEN	Genset Mode:	<input type="button" value="Auto"/>	Start SOC:	40%	Stop SOC:	80%	Rated Power:	0005.0kVA	<table border="1" style="width: 100%; border-collapse: collapse;"> <tr> <td colspan="2" style="text-align: center; padding: 5px;">GRID</td> </tr> <tr> <td style="padding: 5px;">GRID:</td> <td style="text-align: right; padding: 5px;">GEN</td> </tr> <tr> <td style="padding: 5px;">Genset Mode:</td> <td style="text-align: right; padding: 5px;"><input type="button" value="Auto"/></td> </tr> <tr> <td style="padding: 5px;">Startup of Voltage:</td> <td style="text-align: right; padding: 5px;">45.0V</td> </tr> <tr> <td style="padding: 5px;">Stop of Voltage:</td> <td style="text-align: right; padding: 5px;">55.0V</td> </tr> <tr> <td style="padding: 5px;">Rated Power:</td> <td style="text-align: right; padding: 5px;">0005.0kVA</td> </tr> </table>	GRID		GRID:	GEN	Genset Mode:	<input type="button" value="Auto"/>	Startup of Voltage:	45.0V	Stop of Voltage:	55.0V	Rated Power:	0005.0kVA
GRID																									
GRID:	GEN																								
Genset Mode:	<input type="button" value="Auto"/>																								
Start SOC:	40%																								
Stop SOC:	80%																								
Rated Power:	0005.0kVA																								
GRID																									
GRID:	GEN																								
Genset Mode:	<input type="button" value="Auto"/>																								
Startup of Voltage:	45.0V																								
Stop of Voltage:	55.0V																								
Rated Power:	0005.0kVA																								

4. BACKUP: BACKUP: This port can be set as Disable or Enable. This port can connect to the smart load.

BACKUP	
BACKUP:	<input type="button" value="Enable"/>

5. GEN: There are 3 options for this port, Disable, GEN and Smart Load. Specially, if Grid port is set as GEN, the selection of GEN in this port will be hidden. Choosing GEN in GEN port is as same as it in the Grid port. If GEN is selected, the generator icon will appear in the lower center of the Energy Flow Diagram, generator icon will be replaced as smart load icon if Smart Load is selected, while nothing shows if port is set as Disable.

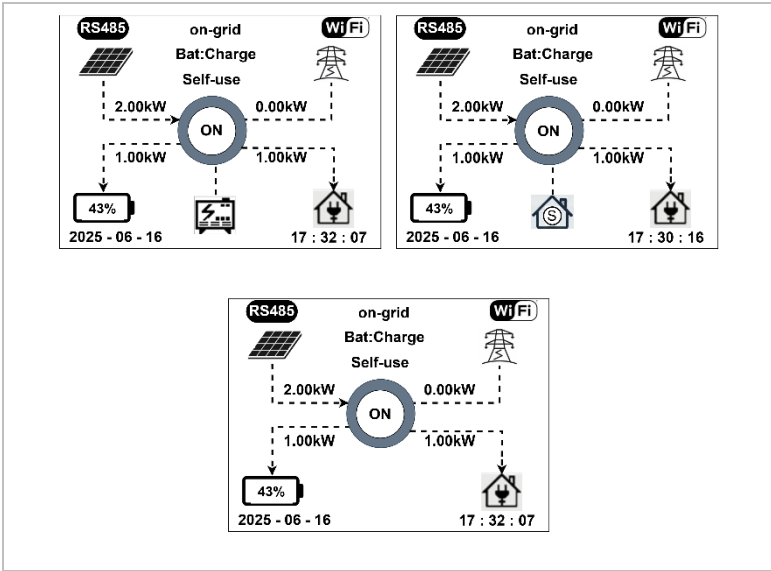

Smart Load has 4 control modes, including Normally on, normally off, Smart Mode and Timing Mode. Particularly, Smart Mode can be controlled by SOC or battery voltage depend on the battery type connected to the inverter, lead acid battery or lithium battery.

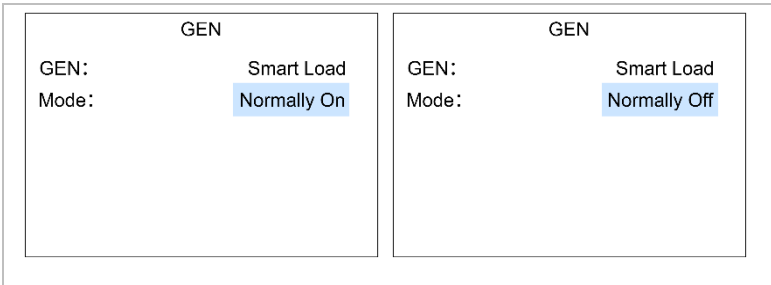

GEN		GEN	
GEN:	Smart Load	GEN:	Smart Load
Mode:	Smart Mode	Mode:	Timing Mode
Startup Power:	0005.0kW	Time:	00:00-23:59
Startup of Voltage:	57.6V	Date:	01.01-12.31
Stop of Voltage:	46.0V	Weekday:	Mon. Tue. Wed. Thu. Fri. Sat. Sun.

5. Work Mode

Select “5. Work Mode”, press “Confirm” to enter the work mode and the energy storage settings interface. Please refer to section **7.3.8 Work Mode** for more details.

<p style="text-align: center;">Work Mode</p> <ul style="list-style-type: none"> 1.Self-use 2.Feed-in Priority 3.Peak Shaving 4.Time of Use 5.Passive 	<p style="text-align: center;">Energy Storage Settings</p> <table border="0"> <tr> <td>Charge Limit SOC</td> <td style="text-align: right;">100%</td> </tr> <tr> <td>On-Grid Discharge Limit SOC</td> <td style="text-align: right;">020%</td> </tr> <tr> <td>Off-Grid Discharge Limit SOC</td> <td style="text-align: right;">010%</td> </tr> <tr> <td>Off-Grid Recovery Discharge SOC</td> <td style="text-align: right;">015%</td> </tr> </table>	Charge Limit SOC	100%	On-Grid Discharge Limit SOC	020%	Off-Grid Discharge Limit SOC	010%	Off-Grid Recovery Discharge SOC	015%
Charge Limit SOC	100%								
On-Grid Discharge Limit SOC	020%								
Off-Grid Discharge Limit SOC	010%								
Off-Grid Recovery Discharge SOC	015%								

6. RS485 Communication

Select “RS485 Communication”, press “Confirm” to enter communication setting interface.

Set the communication address from 001 to 247, and the default is 001.

<p>RS485 Communication</p> <ul style="list-style-type: none"> 1.Address 2.Baud Rate

1. Address: Set the communication address from 001 to 247, and the default is 001.

Address

001

2.Baud Rate: Only 2 options, 9600 or 115200 baud rate, and the default is 9600.

Baud Rate

9600
115200

7.3.6 Advanced Settings

User can input level 1 or level 2 password to enter the interface of advanced settings, including 15 options.

For the level 2 password, please consult the representative of TUNCMATIK.

1.System Information	
2.Real-time Information	
3.Event List	
4.Energy Statistics	
5.System Settings	
6.Advanced Settings	-----Level 1 Password "0001"
7.Software Update	1.Battery
	2.Feed-in Limit Control

3.IV Curve Scan
4. Logic Interface
5.Restore Factory Settings
6.Parallel Settings
7. Unbalanced Support
8.Switch On/Off
9.PCC Import Limit
10.Set PCC Power Offset
11.BACKUP GFCI
12. Neutral Point Grounding
13. E-STOP
14. PCC Meter/CT
15. Backup PV

1. Battery

Select "1. Battery" to enter the interface of battery settings.

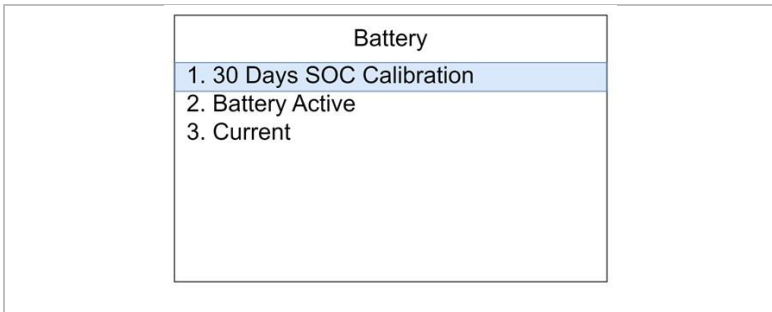

1.30 days SOC Calibration: Select it and press "Confirm" to enter the battery SOC auto-calibration setting interface. Default is "Disable", which means inverter will calibrate soc automatically every 30 days.

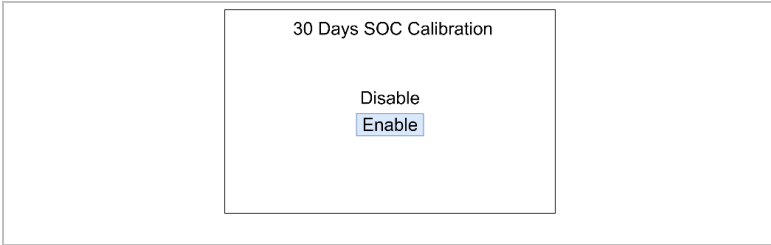

2. Battery Active: Select it and press “Confirm” to enter the active interface. User can enable or disable to automatically activate battery, also user can manually active battery once.

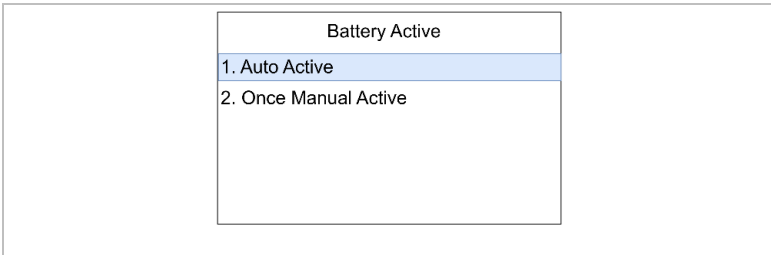

3. Current: Select it and press “Confirm” to enter the battery current setting interface. The user can set the maximum charge and discharge current of the battery.

This is the highest-level setting for battery current. Even if the lithium-ion battery’s BMS allows a higher charge or discharge current, the inverter will still limit the current at the battery port according to this set value.

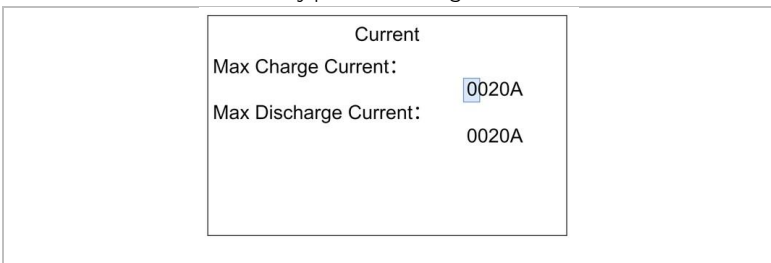

2. Feed-in Limit Control

Select “2. Feed-in Limit Control” to enter the settings interface. User can enable or disable feed-in limitation mode, and user can also set the feed-in limit power.

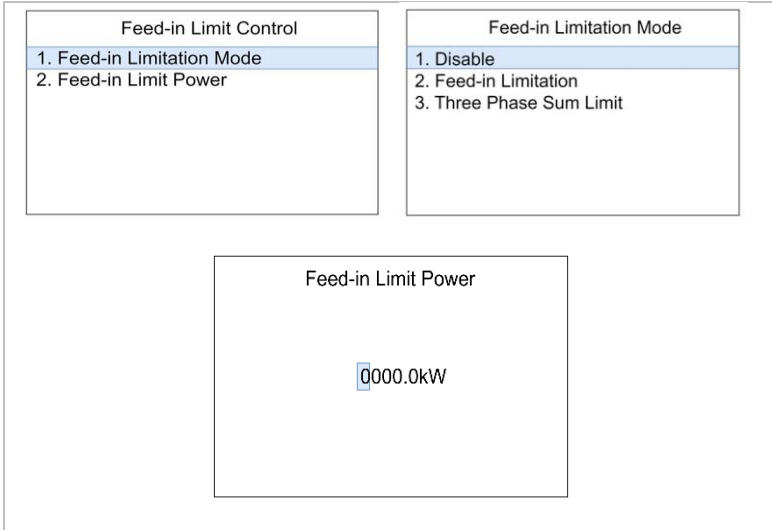

3. IV Curve Scan

Select “3. IV Curve Scan” to enter the settings interface. User can enable or disable scan control and set the scanning period. User can also manually scan once.

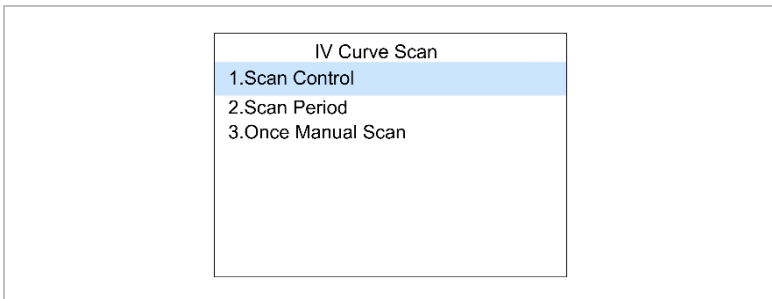

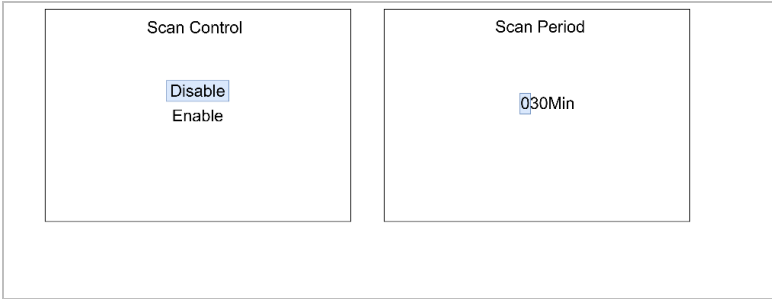

4. Logic Interface

Select "4. Logic Interface" to enter the settings interface. User can enable or disable DRM0 and DRMn.

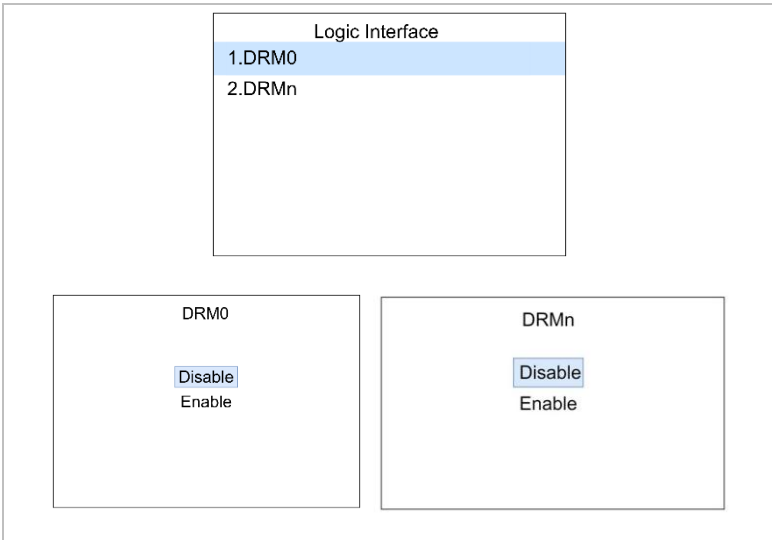

5. Restore Factory Settings

Select "5. Restore Factory Settings" to enter the reset interface.

"1. Clear Energy Data" will clear all energy data in "Energy Statistic".

"2. Clear Events" will clear all events in "Event list".

"3. Reset Settings" will reset all user settings to the default state.

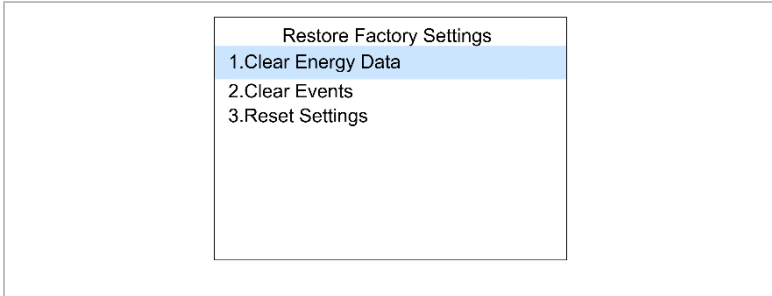

6. Parallel Settings

Select "6. Parallel Settings" to enter the setting interface.

User can enable or disable the parallel control. If Parallel Control is set as disable, the interface will hide Master-Slave setting.

If the inverter is set as Slave, user need to set the parallel address in the whole parallel system.

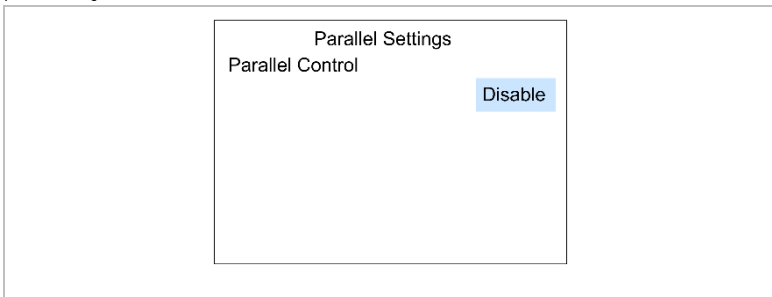

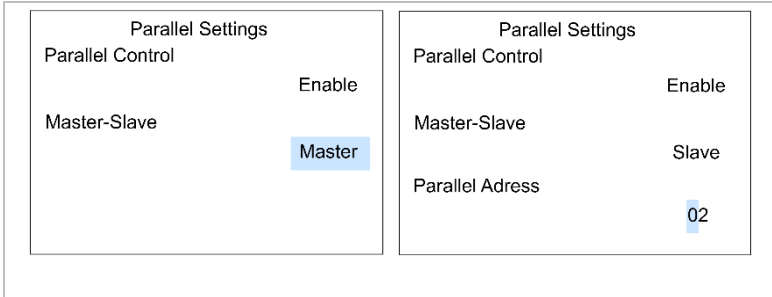

7. Unbalanced Support

Select "7. Unbalanced Support" to enter the interface.

When the inverter is connected to a three-phase three-wire system(3P3W), this function must be disabled. In this case, the relay on the Neutral line will open, and the inverter will output equal power on all phases.

When the inverter is connected to a three-phase four-wire system(3P4W), this function must be enabled. In this case, the relay on the Neutral line will close, and the inverter will independently control the power of each phase according to the load characteristics.

In addition, if the Backup Port is enabled, this function will be enabled by default and cannot be disabled.

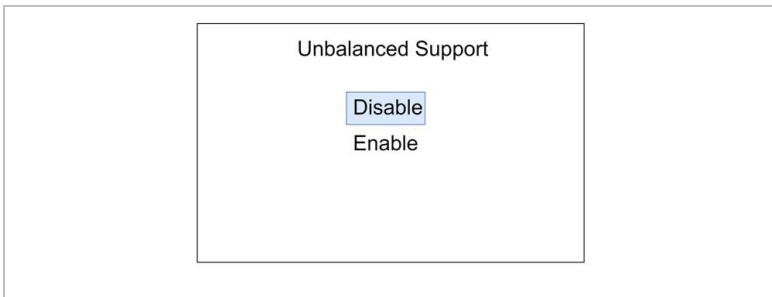

8. Switch On/Off

Select "8. Switch On/Off" to enter the interface. User can switch on or switch off the machine.

Inverter will switch on automatically after completing first-time settings.

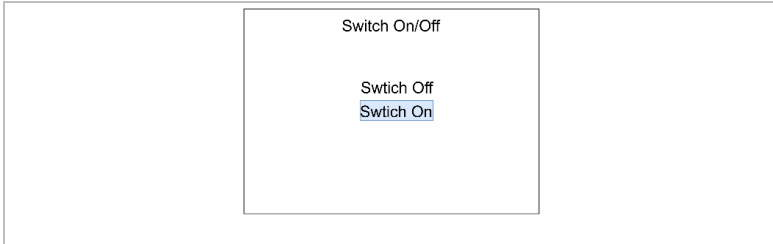

9. PCC Import Limit

Select "9. PCC Import Limit Control" to enter the interface. User can enable or disable the PCC limit control and set the PCC import limit power.

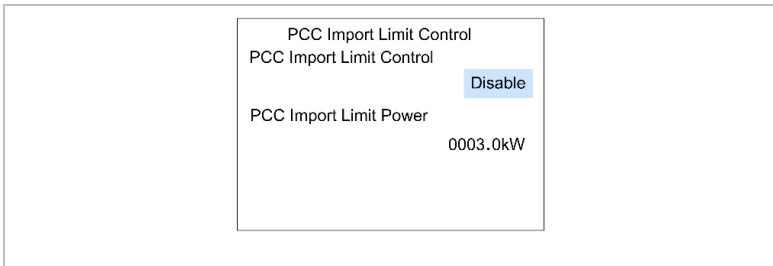

10. Set PCC Power Offset

Select "10. Set PCC Power Offset" to enter the interface. Users can manually calibrate the PCC-side power on this page.

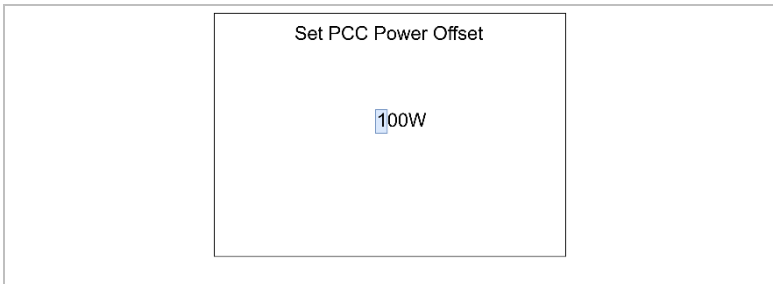

11. BACKUP GFCI

Select "11. BACKUP GFCI" to enter the interface. User can enable or disable the function. When this function is disabled, the inverter will not perform GFCI detection and protection during off-grid status.

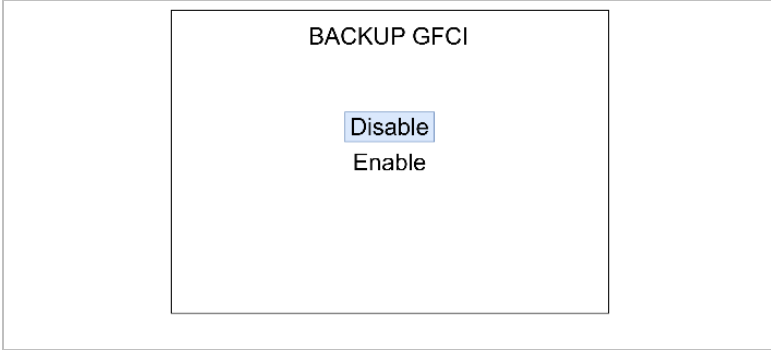

12. Neutral Point Grounding

Select "12. Neutral Point Grounding" to enter the setting interface. User can enable or disable the function. When this function is disabled, the inverter will NOT close the relays between the neutral and ground in off-grid status. More details please refer to section 5.8 System electrical topology.

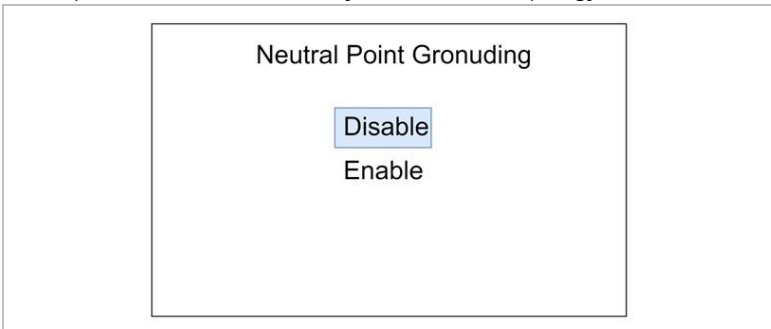

13. E-Stop

Select “13. E-Stop” to enter the setting interface. User can enable or disable the function of emergency stop.

If this function is enabled, an external emergency-stop (E-stop) switch must be used, with its normally closed (NC) contact connected to the G-DI terminal of the communication port.

When the E-stop switch is not pressed, the contact remains closed and the inverter operates normally.

When the E-stop switch is pressed, the inverter detects the open contact and immediately stops power output and switches to the shutdown state.

This function is disabled by default.

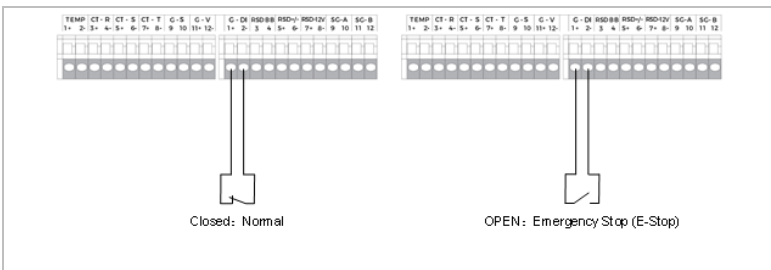
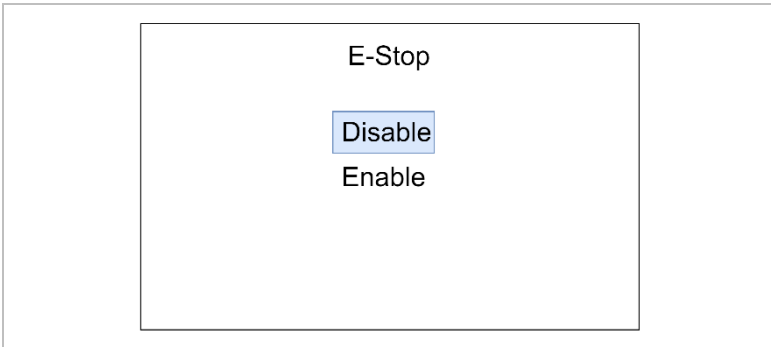

14. PCC Meter/CT

Select "14. PCC Meter/CT" to enter the setting interface.

If the user employs a CT or energy meter to measure the current/power at the grid point of common coupling (PCC), this function must be enabled.

If neither a CT nor an energy meter is used, this function must be disabled.

Incorrect configuration may lead to abnormal operation or false fault alarms.

This function is enabled by default.

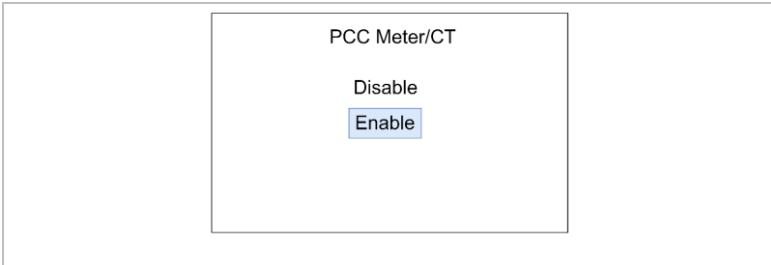

15. BACKUP PV

Select "15. BACKUP PV" to enter the setting interface. User can enable or disable the function.

When the function is disabled, the backup port will output voltage only when a battery or the AC grid is present.

When this function is enabled, the inverter can also supply voltage to the backup port using PV power alone.

This function is disabled by default.

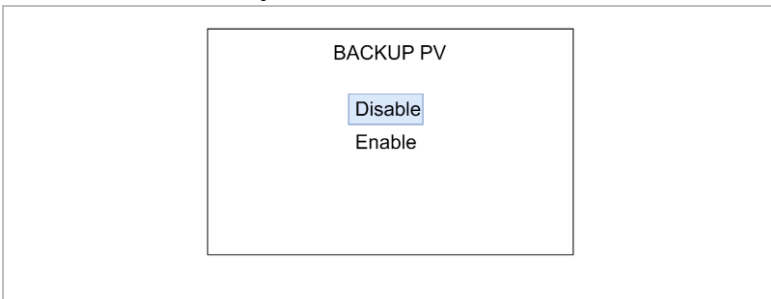

7.3.7 Firmware Update

User can input level 2 password to enter the updating interface, including two kinds of device, Inverter and Battery. For the level 2 password, please consult the representative of TUNCMATIK.

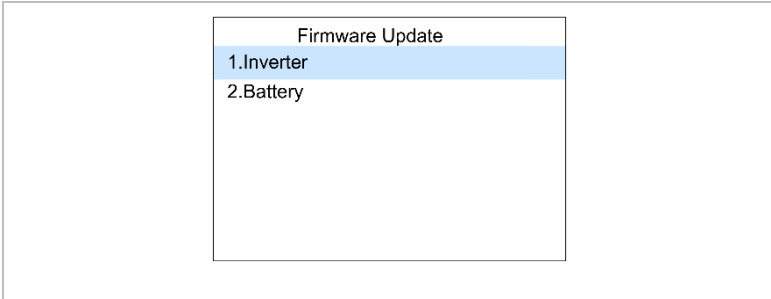

Select the device and press "Confirm" after u-disk plugged in, it will show the firmware version for updating. It will show the prompt "No U-Disk" if there is no u-disk connected.

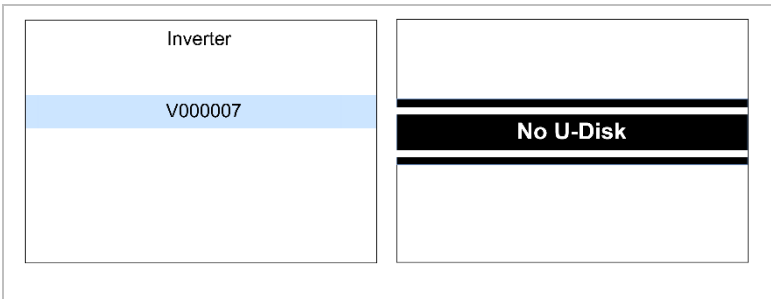

- ▶ The firmware needs to be placed in the folder named "**firmware**" located in the root directory of the u-disk.
- ▶ There are 4 parts firmware of Inverter with the same version numbers in the filename, while Battery has 2 parts. The interface will not display the selection of updating version if lack of any firmware part.

Select the version and press “Confirm” to update Inverter device, user can decide to update the safety parameters or not by selecting Confirm or Cancel.

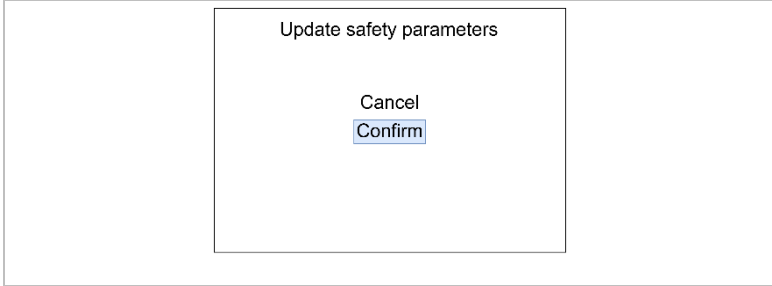

After copying the firmware from u-disk completely, device starts to update, Inverter update order: part2, part3, part4 and part1. Battery update order: part1, part2. Inverter or Battery will reboot immediately once update successfully.

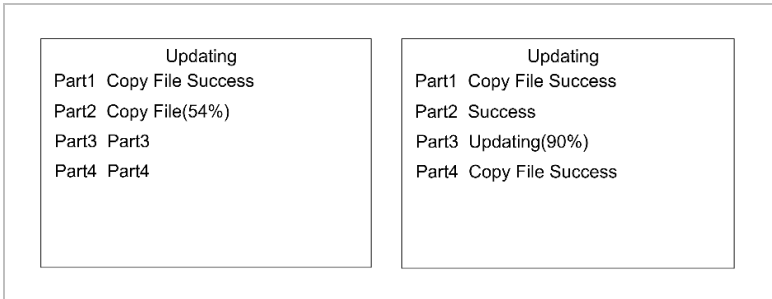

7.3.8 Work Mode

When the inverter is in on-grid state, there are five modes to work, including Self-use, Feed-in Priority, Peak Shaving, Time-of-use and Passive.

1. Self-use

PV Energy Supply Priority depends on the Battery Priority Control setting item. Load Energy Consumption Priority: PV > Battery > Grid.

Settings	Description
Battery First	When Battery First is set as Disable, the PV Energy Supply Priority is Load > Battery > Grid. The power from PV supplies the loads first. After that, if there is excess PV power, charges the battery first and then feeds into the grid.
Battery Priority Cut-off SOC	When Battery First is set as Enable, user need to set the Battery First Cut-off SOC. The PV Energy Supply Priority is Battery > Load > Grid when battery SOC is less than the Battery First Cut-off SOC. The PV power charges the battery first. After that, if there is excess PV power, supplies the loads first and then feeds into the grid.
Charging From Grid	When Charging From Grid setting is enabled and the battery soc is less than the Charge Cut-off SOC, it will force the battery to charge with the Charging Power Limit. When the battery SOC exceeds the Charge Cut-off SOC, the battery will no longer be forced to charge. The setting of Charging From Grid only works during effective time period, according to the Time, Date, Weekday settings.
T/D(Time/Date)	
Weekday	
Charging Power Limit	
Charge Cut-off SOC	

<p style="text-align: center; margin: 0;">Self-use</p> <p>Battery First: Disable</p> <p>Charging From Grid: Disable</p>	<p style="text-align: center; margin: 0;">Self-use</p> <p>Battery First: Enable</p> <p>Battery First Cut-off SOC: 080%</p> <p>Charging From Grid: Disable</p>
<p style="margin: 0;">Self-use</p> <p>Battery First: Enable</p> <p>Battery First Cut-off SOC: 080%</p> <p>Charging From Grid: Enable</p> <p>T/D: 00:00-23:59 01.01-12.31</p> <p>Weekday: Mon. Tue. Wed. Thu. Fri. Sat. Sun.</p> <p>Charging Power Limit: 01000W</p> <p>Charge Cut-off SOC: 100%</p>	

2. Feed-in Priority

PV Energy Supply Priority: Load > Grid > Battery.

Load Energy Consumption Priority: PV > Battery > Grid.

Settings	Description
Feed-in Power	<p>PV Power < Load Power. The PV and battery supply power to the loads at the same time.</p> <p>PV Power - Load Power ≤ Feed-in Power. The power generated from PV is directly supplied to the loads first. The excess power beyond the load consumption will be fed into the grid.</p> <p>PV Power - Load Power > Feed-in Power. The power generated from PV is directly supplied to the loads first. Then the power fed to the grid reaches the Feed-in Power and the excess power charges the battery.</p>

3. Peak Shaving

PV Energy Supply Priority: Load > Battery > Grid.

Load Energy Consumption Priority: PV > P_import > Battery > Grid.

P_import represents Import Power Limit, which means the maximum power that can be purchased from the grid with priority before battery starts to supply the load consumption

Settings	Description
Import Power Limit	<p>When the PV energy is insufficient to supply the load, import from the grid to supply the load firstly. When the power from the grid exceeds the Import Power Limit, the battery will discharge to supply the load.</p>
Charging From Grid	
Charge Cut-off SOC	<p>If PV Power + Import Power Limit + Battery Max Discharge Power < Load Power, the insufficient power will import from grid.</p> <p>If PV Power + Priority Import Power - Load Power > 0, and Charging From Grid is enabled, the excess power will charge the battery until the battery SOC reaches the Charge Cut-off SOC. Otherwise, the battery will stay in standby state if Charging From Grid is disabled.</p>

<p style="text-align: center;">Peak Shaving</p> <p>Import Power limit: 0001.0kW</p> <p>Charging From Grid: Disable</p>	<p style="text-align: center;">Peak Shaving</p> <p>Import Power limit: 0001.0kW</p> <p>Charging From Grid: Enable</p> <p>Charge Cut-off SOC: 100%</p>
---	---

4. Time-of-use

In the Time-of-use, includes not only Charge and Discharge modes, but also the Peak Shaving, Feed-in Priority and Self-use previously mentioned.

There are 5 rules to set in this mode, each one can be disabled or enabled. If a rule is enabled, user must set the mode, time, date, weekday and detailed parameters based on the mode. Once two rules effect in the same time, for instance, rule 1 for Self-use and rule 3 for Discharge, the inverter will choose the lower number rule which is rule 1 to execute Self-use working mode smartly. Charge and Discharge are simple, just force the battery to charge or discharge at the setting power during the effective time. Others have the same functionality as the previous working mode.

<p style="text-align: center;">Time-of-use</p> <p>Rules 1: Enable</p> <p>Mode: Charge</p> <p>Time: 01:00-05:00</p> <p>Date: 01.01-12.31</p> <p>Weekday: Mon. Tue. Wed. Thu. Fri. ---. Sun.</p> <p>Power: 02500W</p> <p>SOC: 100%</p>	<p style="text-align: center;">Time-of-use</p> <p>Rules 2: Enable</p> <p>Mode: Discharge</p> <p>Time: 01:00-05:00</p> <p>Date: 01.01-12.31</p> <p>Weekday: Mon. Tue. Wed. Thu. Fri. Sat. Sun.</p> <p>Power: 02500W</p> <p>SOC: 100%</p>
--	---

<p style="text-align: center;">Time-of-use</p> <p>Rules 3: Enable</p> <p>Mode: Peak Shaving</p> <p>Time: 01:00-05:00</p> <p>Date: 01.01-12.31</p> <p>Weekday: Mon. Tue. Wed. Thu. Fri. Sat. Sun.</p> <p>Charging From Grid: Disable</p> <p>Power-SOC: 0002.5kW-100%</p>	<p style="text-align: center;">Time-of-use</p> <p>Rules 4: Enable</p> <p>Mode: Feed-in Priority</p> <p>Time: 01:00-05:00</p> <p>Date: 01.01-12.31</p> <p>Weekday: Mon. Tue. Wed. Thu. Fri. Sat. Sun.</p> <p>Power: 0002.5kW</p>
--	--

<p style="text-align: center;">Time of use Mode</p> <p>Rule 5: Enable</p> <p>Mode: Self-use</p> <p>Time: 04:00-14:00</p> <p>Date: 01.01-12.31</p> <p>Weekday: Mon. Tue. Wed. Thu. Fri. Sat. Sun.</p> <p>Import to Charge Battery: Enable</p> <p>Power/SOC: 02000W-090%</p>

5. Passive

When passive mode is selected as the working mode, the power scheduling of the inverter is controlled by external commands.

For more detailed information, please ask representative of TUNCMATIK to get a copy of passive mode communication protocol.

7.4 Power-On Step

IMPORTANT: Every time the battery restarts, the inverter also needs to be turned on again.

Step1 Turn ON the DC circuit breaker between battery and inverter.

Step2 Activate the lithium-ion battery if you have one.

Step3 Turn on the PV switch on the inverter.

Step4 Turn ON the AC circuit breaker between the inverter the Backup port and critical load.

Step5 Turn ON the AC circuit breaker between the inverter GRID port and the power grid.

Step6 Press the DC button on the inverter.

NOTE: Open it in a standard order. If this operation has not been performed normally, all problems caused will be borne by the user. Tuncmatik does not take any responsibility for the property destruction and personal injury because of any incorrect use.

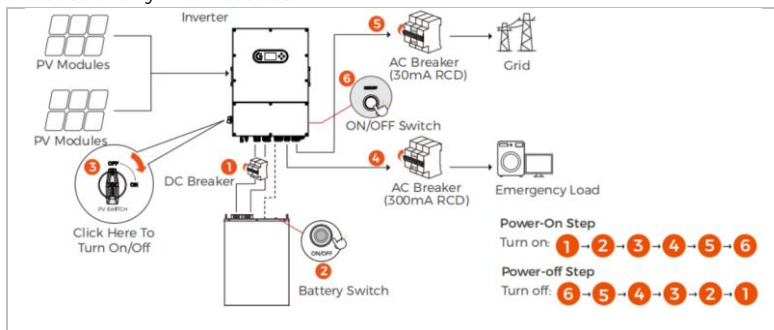

7.5 Power-off Step

Step1 Press the DC button on the inverter to set it to the “released” position.

Step2 Turn Off the AC circuit breaker between the inverter GRID port and the power grid.

Step3 Turn Off the AC circuit breaker between the inverter the Backup port and critical load.

Step4 Turn Off the PV switch on the inverter.

Step5 Deactivate the lithium-ion battery.

Step6 Turn Off the DC isolator between battery and inverter.

NOTE: Close it in a standard order. If this operation has not be performed normally, all problems caused will be borne by the user, nothing to do with the company.

8 Troubleshooting

This section contains information and procedures for solving possible problems with the inverter.

This section helps users to identify the inverter fault. Please read the following procedures carefully:

Check the warning, fault messages or fault codes shown on the inverter screen, record all the fault information.

If there is no fault information shown on the screen, check whether the following requirements are met:

- ▶ - Is the inverter mounted in a clean, dry place with good ventilation?
- ▶ - Is the DC switch turned ON?
- ▶ - Are the cables adequately sized and short enough?
- ▶ - Are the input and output connections and wiring in good condition?
- ▶ - Is the configuration Settings correct for the particular installation?
- ▶ - Are the display panel and the communication cables properly connected and undamaged?

Follow the steps below to view recorded problems: Press "Back" to enter the main menu in the normal interface. In the interface screen select "Event List", then press "OK" to enter events.

▶ Earth Fault Alarm

This inverter complies with IEC 62109-2 clause 13.9 for earth fault alarm monitoring.

If an Earth Fault Alarm occurs, the fault will be displayed on the LCD screen, the red light will be on, and the fault can be found in the history of the fault. For the machine installed with Wi-Fi/GPRS, the alarm information can be seen on the corresponding monitoring website, and can also be received by the APP on the mobile phone.

► **Event List information**

Table 8-1 Event List

Code	Name	Description	Solution
ID001	GridOVP	The grid voltage is too high	If the alarm occurs occasionally, the possible cause is that the electric grid is abnormal. Inverter will automatically return to normal operating status when the electric grid's back to normal.
ID002	GridUVP	The grid voltage is too low	
ID003	GridOFP	The grid frequency is too high	
ID004	GridUFP	The grid frequency is too low	<p>If the alarm occurs frequently, check whether the grid voltage/frequency is within the acceptable range. If yes, please check the AC circuit breaker and AC wiring of the inverter.</p> <p>If the grid voltage/frequency is NOT within the acceptable range and AC wiring is correct, but the alarm occurs repeatedly, contact technical support to change the grid over-voltage, under-voltage, over-frequency, under-frequency protection points after obtaining approval from the local electrical grid operator.</p>
ID005	GFCI	Charge Leakage Fault	Internal faults of inverter, switch OFF inverter, wait for 5 minutes, then switch ON inverter. Check whether the problem is solved.
ID006	OVRT	Over Voltage Ride Through function is faulty	

Code	Name	Description	Solution
ID007	LVRT	Low Voltage Ride Through function is faulty	
ID008	IslandFault	Island protection error	
ID009	GridOVPIstant1	Transient overvoltage of grid voltage 1	
ID010	GridOVPIstant2	Transient overvoltage of grid voltage 2	
ID012	InvVoltFault	Inverter voltage error	
ID013	RefluxOverload	Feed-in limitation overload	
ID017	HwADFaultIGrid	Power grid current sampling error	
ID018	HwADFaultDCI	Wrong sampling of dc component of grid current	
ID020	HwADFaultVGri d (AC)	Power grid voltage sampling error (AC)	
ID022	GFCIDeviceFault (AC)	Leakage current sampling error (AC)	
ID024	HwADFaultIdc	DC input current sampling error	

Code	Name	Description	Solution
ID029	ConsistencyFault_GFCI	Leakage current consistency error	
ID030	ConsistencyFault_Vgrid	Grid voltage consistency error	
ID037	HwAuxPowerFault	Auxiliary power error	
ID038	InvSoftStartFail	Inverter soft start failure	
ID041	RelayFail	Relay detection failure	
ID042	IsoFault	Low insulation impedance	Check the insulation resistance between the photovoltaic array and ground (ground), if there is a short circuit, the fault should be repaired in time.
ID045	CTDisconnect	CT error	Check whether the CT wiring is correct.
ID046	ReversalConnection	PV reverse connection	Please check whether the positive negative pole of the PV on the inverter is reversed. If yes, wait until the PV end current is lower than 0.5A, set the "DC Switch" to the "OFF" position and adjust the string polarity.
ID047	ParallelFault	Parallel error	1. Please check whether the parallel cable is correctly connected; 2. Please check whether the parallel setting on the LCD is correct.
ID049	TempFault_Bat	Battery temperature protection	1. Please check whether the lead-acid battery temperature sensor is installed; 2. Please check whether the connection of the temperature sensor is loose or falls off; 3. If both conditions are normal,

Code	Name	Description	Solution
			check whether the battery temperature is too high or too low. If the fault information still exists, please contact technical support.
ID050	TempFault_Heat Sink1	Heatsink 1 temperature protection	Make sure the inverter is installed where there is no direct sunlight.
ID051	TempFault_Heat Sink2	Heatsink 2 temperature protection	Please ensure that the inverter is installed in a cool/well-ventilated place.
ID052	TempFault_Heat Sink3	Heatsink 3 temperature protection	Ensure the inverter is installed vertically and the ambient temperature is below the inverter temperature limit.
ID057	TempFault_Env1	Ambient temperature 1 protection	<p>Make sure the inverter is installed where there is no direct sunlight.</p> <p>Please ensure that the inverter is installed in a cool/well-ventilated place.</p> <p>Ensure the inverter is installed vertically and the ambient temperature is below the inverter temperature limit.</p>
ID067	BusUVP	Busbar undervoltage during grid-connection	<p>Internal faults of inverter, switch OFF inverter, wait for 5 minutes, then switch ON inverter. Check whether the problem is solved.</p> <p>If no, please contact technical support.</p>

Code	Name	Description	Solution
ID069	PVOVP	PV over-voltage	Check whether the PV series voltage (Voc) is higher than the maximum input voltage of the inverter. If so, adjust the number of PV modules in series and reduce the PV series voltage to fit the input voltage range of the inverter. After correction, the inverter will automatically return to its normal state.
ID070	BatOVP	Battery over-voltage	Check whether the battery overvoltage setting is inconsistent with the battery specification.
ID072	SwBusRmsOVP	Inverter bus voltage RMS software overvoltage	Internal faults of inverter, switch OFF inverter, wait for 5 minutes, then switch ON inverter. Check whether the problem is solved. If no, please contact technical support.
ID073	SwBusInstantOVP	Inverter bus voltage instantaneous value software overvoltage	
ID081	SwBatOCP	Battery overcurrent software protection	
ID086	SwPvOCPInstant	PV overcurrent software protection	
ID091	ResOver	Battery input hardware protection	
ID096	EpsLoadShortCircuit	EPS short circuit protection	If the fault has been detected for three times, wait 30 minutes before entering the off-grid working mode again. Please check whether the AC

Code	Name	Description	Solution
			LOAD port is connected correctly.
ID098	HwBusOVP	Inverter bus hardware overvoltage	Internal faults of inverter, switch OFF inverter, wait for 5 minutes, then switch ON inverter. Check whether the problem is solved. If no, please contact technical support.
ID100	HwBatOCP	Battery hardware overcurrent	
ID102	HwPVOCP	PV hardware overcurrent	
ID103	HwACOCP	Ac output hardware overcurrent	
ID105	MeterCommFault	Meter communication error	Please check whether the meter is connected and whether the meter parameters are set correctly.
ID108	GeneratorStartupFail	Generator startup failure	1.Check whether the generator is in good condition; 2. Check whether the generator and inverter are properly connected.
ID109	GeneratorOverload	Generator overload	Please check whether the generator is working under overload condition.
ID110	Overload1	Overload protection 1	Please check whether the inverter is operating under overload.
ID111	Overload2	Overload protection 2	
ID124	BatLow	Warning of low battery level	Please check whether the battery SOC or voltage is too low.
ID145	USBFault	USB fault	Check the USB port of the inverter.
ID147	BluetoothFault	Bluetooth fault	Check the Bluetooth connection of the inverter.

Code	Name	Description	Solution
ID150	FlashFault	Communication board FLASH error	Internal faults of inverter, switch OFF inverter, wait for 5 minutes, then switch ON inverter. Check whether the problem is solved. If no, please contact technical support.
ID152	SafetyVerFault	Safety version error	
ID153	SCIlose(DC)	SCI communication error (DC)	
ID154	SCIlose(AC)	SCI communication error (AC)	
ID156	SoftVerError	Inconsistent software versions	Contact for technical support and software upgrades.
ID157	BMSCommFault	Communication failure of lithium battery	Make sure your battery is compatible with the inverter. CAN communication is recommended. Check the communication line or port of the battery and inverter for faults.
ID162	RemoteShutdown	Remote shutdown	The inverter is performed a remote shutdown.
ID163	Drm0Shutdown	Drm0 shutdown	The inverter is performed a Drm0 shutdown.
ID169	FanFault1	Internal Fan fault	Check if the corresponding fan of the inverter is running normally. If the problem is not solved, please contact technical support.
ID170	FanFault2	External Fan fault	
ID177	BMS OVP	BMS over-voltage alarm	Internal failure of lithium battery, close inverter and lithium battery, and wait 5 minutes to open inverter and lithium battery. Check that the problem is
ID178	BMS UVP	BMS under-voltage alarm	

Code	Name	Description	Solution
ID179	BMS OTP	BMS high temperature warning	resolved. If not, please contact technical support.
ID180	BMS UTP	BMS low temperature alarm	
ID181	BMS OCP	Warning of overload in charge and discharge of BMS	
ID182	BMS Short	BMS short circuit alarm	
ID186	BatDischargeHT P	Battery discharge over temperature protection	Make sure the battery is operating within its normal temperature range. Power off and wait for 2 hours. If the problem is not solved, please contact technical support.
ID187	BatDischargeLT P	Battery discharge low temperature protection	
ID188	BatChargeHTP	Battery charge over temperature protection	
ID190	BatChargeLTP	Battery charge low temperature protection	
ID274	ConsistentFault Vbus	Bus voltage consistency error	

▶ **Maintenance**

Inverters generally do not need any daily or routine maintenance. Heat sink should not be blocked by dust, dirt or any other items. Before the cleaning, make sure that the DC switch is turned OFF and the circuit breaker between inverter and electrical grid is turned OFF. Wait at least for 5 minutes before the Cleaning.

▶ **Inverter cleaning**

Please clean the inverter with an air blower, a dry and soft cloth or a soft bristle brush. Do NOT clean the inverter with water, corrosive chemicals, detergent, etc.

▶ **Heat sink cleaning**

For the long-term proper operation of inverters, ensure there is enough space around the heat sink for ventilation, check the heat sink for blockage (dust, snow, etc.) and clean them if they exist. Please clean the heat sink with an air blower, a dry and soft cloth or a soft bristle brush. Do not clean the heat sink with water, corrosive chemicals, detergent, etc.

9 Datasheet

► The following parameters may change without notice, please refer to the User Manual and Datasheet on our website.

Technical Data	THY-T10K-LV	THY-T12K-LV	THY-T15K-LV	THY-T20K-LV
Battery Parameters				
Battery type	Lithium-ion and Lead-acid			
Number of Battery Input Channels	1			
Battery voltage range	40-60 Vd.c.			
Max charging power	12 kW		20 kW	
Max. Discharging Power	10 kW	12 kW	15 kW	20kW
Maximum charging current	240 A		350 A	
Maximum discharging current	210A	240 A	300 A	350A
BMS Communication	RS-485/CAN			
PV Input				
Recommended Max. PV input power (Wp)	20 kWp	24 kWp	30 kWp	40kWp
Max. input voltage	1000 Vd.c.			
Rated input voltage	600 Vd.c.			
Start-up voltage	200 Vd.c.			
MPPT voltage range	160-950 Vd.c.			
Number of MPPT	2			
Max. Number of Input Strings per MPPT	2/2			
Max. Input Current	40/40 A			
Max. Isc	50/50 A			
AC Grid				
Rated Output Power	10 kW	12 kW	15 kW	20 kW
Rated Output Current	15.2/14.5/13.9 A	18.2/17.4/16.7 A	22.8/21.7/20.9 A	30.4/28.9/27.8A
Rated Apparent Power	10 kVA	12 kVA	15 kVA	20 kVA
Max. Apparent Power	11 kVA	13.2 kVA	16.5 kVA	22 kVA
Max. Output Current	16.7/15.9/15.3 A	20.0/19.1/18.3 A	25.1/23.8/23.0 A	33.4/31.8/30.6 A
Max. Input Current	35 A	45 A	50 A	60 A
Rated Output Voltage	3N~+PE,380/400/415 Va.c.			

Technical Data	THY-T10K-LV	THY-T12K-LV	THY-T15K-LV	THY-T20K-LV
Rated Output Frequency	50/60 Hz			
Power Factor Range	0.8 lagging-0.8 leading			
THDi	<3%			
AC Backup				
Rated Output Power	10 kW	12 kW	15 kW	20 kW
Rated Output Current	15.2/14.5/13.9 A	18.2/17.4/16.7 A	22.8/21.7/20.9 A	30.4/28.9/27.8A
Rated Apparent Power	10 kVA	12 kVA	15 kVA	20 kVA
Max. Apparent power	11 kVA	13.2 kVA	16.5 kVA	22 kVA
Max. output current	16.7/15.9/15.3 A	20.0/19.1/18.3 A	25.1/23.8/23.0 A	33.4/31.8/30.6 A
Peak Output Apparent Power	2 times of rated power, 10s			
Rated Output Voltage	3N~+PE,380/400/415 Va.c.			
Rated Output Frequency	50/60 Hz			
THDv (@Liner load)	<3%			
Switch time	4 ms(default)			
AC Smartload/Generator				
Rated Output Voltage	3N~+PE,380/400/415 Va.c.			
Rated Output Frequency	50/60 Hz			
Rated Output Power	10 kW	12 kW	15 kW	20 kW
Rated Output Current	15.2/14.5/13.9 A	18.2/17.4/16.7 A	22.8/21.7/20.9 A	30.4/28.9/27.8A
Rated Apparent Power	10 kVA	12 kVA	15 kVA	20 kVA
Max. Apparent Power	11 kVA	13.2 kVA	16.5 kVA	22 kVA
Max. Output Current	16.7/15.9/15.3 A	20.0/19.1/18.3 A	25.1/23.8/23.0 A	33.4/31.8/30.6 A
Efficiency And Protection				
Max. MPPT Efficiency	99.90%			
European Efficiency	97.00%			
Max. Efficiency	97.60%			
Max. Efficiency of Charging/Discharging	95.00%			
Protection				
DC Switch	Yes			
PV Reverse Connection Protection	Yes			
Output Short Circuit Protection	Yes			

Technical Data	THY-T10K-LV	THY-T12K-LV	THY-T15K-LV	THY-T20K-LV
Output Over current Protection			Yes	
Output Overvoltage Protection			Yes	
Insulation Impedance Detection			Yes	
Residual Current Detection			Yes	
Anti-island Protection			Yes	
Surge Protection		PV: Type II, AC: Type II		
General Data				
Dimensions(W*H*D)	485*690*290 mm			
Weight	52 kg			
Inverter Topology	Non-Isolation			
Protective Class	Class I			
Standby Self consumption	<15 W			
Operating Temperature Range	-30°C to +60°C (derating above +45°C)			
Relative Humidity Range	5%~95%			
Max. Operating Altitude	4000 m (derating above 2000 m)			
Cooling Mode	Intelligent Airflow			
IP Rating	IP66			
Overvoltage Category	AC III, DC II			
Installation Method	Wall Mounted			
Display	LCD & APP			
Communication	RS485, Optional: Wi-Fi/4G/LAN			

10 Quality Assurance

Standard warranty period

The standard warranty period of inverter is 60 months (5 years). There are two calculation methods for the warranty period:

Purchase invoice provided by the customer: the first flight provides a standard warranty period of 60 months (5 years) from the invoice date;

The customer fails to provide the invoice: from the production date (according to the SN number of the machine) Our company provides a warranty period of 63 months (5.25 years).

In case of any special warranty agreement, the purchase agreement shall prevail.

Extended warranty period

Within 12 months of the purchase of the inverter (based on the purchase invoice) or within 24 months of the production of the inverter (SN number of machine, based on the first date of arrival), Customers can apply to buy extended warranty products from the company's sales team by providing the product serial number, our company may refuse to do not conform to the time limit extended warranty purchase application. Customers can buy an extended warranty of 5, 10, 15 years.

If the customer wants to apply for the extended warranty service, please contact the sales team of our company. to purchase the products that are beyond the purchase period of extended warranty but have not yet passed the standard quality warranty period. Customers shall bear different extended premium.

During the extended warranty period, PV components GPRS, WIFI and lightning protection devices are not included in the extended warranty period. If they fail during the extended warranty period, customers need to purchase and replace them from our company.

Once the extended warranty service is purchased, our company will issue the extended warranty card to the customer to confirm the extended warranty period.

Invalid warranty clause

Equipment failure caused by the following reasons is not covered by the warranty:

The "warranty card" has not been sent to the distributor or our company;

Without the consent of our company to change equipment or replace parts;

Use unqualified materials to support our company's products, resulting in product failure;

Technicians of non-company modify or attempt to repair and erase the product serial number or silk screen;

Incorrect installation, debugging and use methods;

Failure to comply with safety regulations (certification standards, etc.);

Damage caused by improper storage by dealers or end users;

Transportation damage (including scratches caused by internal packaging during transportation). Please claim directly from the transportation company or insurance company as soon as possible and obtain damage identification such as container/package unloading;

Failure to follow the product user manual, installation manual and maintenance guidelines;

Improper use or misuse of the device;

Poor ventilation of the device;

The product maintenance process does not follow relevant standards;

Failure or damage caused by natural disasters or other force majeure (such as earthquake, lightning strike, aware fire, etc.).

Statement

If you have purchased this product in Australia, you should be aware that this warranty is provided in addition to other rights and remedies held by a consumer at law.

Our goods come with guarantees that cannot be excluded under the Australian Consumer Law. You are entitled to a replacement or refund for a major failure and compensation for any other reasonably foreseeable loss or damage. You are also entitled to have the goods repaired or replaced if the goods fail to be of acceptable quality and the failure does not amount to a major failure.