

User Manual



**7 KW - 21 KW
AC EV Charger**

Version: 1.0













Table of Contents







1. Safety Instructions	1
2. Technical Specifications.....	3
3. Introduction	5
3.1. Product Overview.....	5
3.2. Dimensioned Drawing	7
4. Packaging	8
5. Installation.....	9
5.1. Pre-Installation	9
5.2. Cable Reach	13
5.3. Construct Foundation	13
5.4. Space Requirement.....	14
5.5. Single Pedestal Installation	16
5.6. AC Charger Installation	19
5.7. Back to Back Pedestal Installation	22
5.8. Wall-Mount Charger Installation.....	23
6. Mobil Uygulama Kullanım ve Kurulum Kılavuzu	27
6.1 Kayıt ve giriş.....	27
6.2 Cihazın İnternete Bağlanması	31
6.3 TUNÇMATİK HOME CHARGER UYGULAMASI	34
6.4 PLANLI ŞARJ NEDİR, NE İŞE YARAR?	38
6.5 Yazılım Güncellemesi ve Akım Ayarlaması	39
6.6 SWITCH AYARLAMA	40
7. Screen Image.....	41
8. Routine Maintenance	43
9. Trouble Shooting	44

1. Safety Instructions



Read and follow the instructions and warnings in this Manual before attempting to install this product. Keep this Manual for future reference.

Please follow the below safety precautions to prevent bodily injuries and property damages.

HAZARD OF ELECTRIC SHOCK, EXPLOSION, OR ARC FLASH	
	WARNING: Damaging fumes
	WARNING: Explosive mixtures of dust or gases, corrosive gases, or conductive or radiant heat from other source.
	WARNING: Moisture, abrasive dust, steam or in an excessively damp environment.
	WARNING: Fungus, insects, vermin.
	WARNING: Salt-laden air or contaminated cooling refrigerant.
	WARNING: Pollution degree higher than 2 according to IEC 60664-1.
	WARNING: Exposure to abnormal vibrations, shocks, and tilting.
	WARNING: Exposure to direct sunlight, heat sources, or strong electromagnetic fields.
	WARNING: When the product is running, it should pay attention to ventilation, heat dissipation and keep the environment clean. Avoid installation in places with frequent occurrence of storm, rainstorm, lightning and other severe weather.
	WARNING: During installation, if any abnormal phenomena such as cracking, loose case lock, water leakage are showing up, all operations shall be stopped immediately and professionals shall be informed in time to deal with them.
	WARNING: Do not put inflammable, explosive or combustible materials, chemicals, combustible steam and other dangerous goods near the charger.
	WARNING: Please keep the nozzle clean and dry. If there is any dirt, please wipe it with a cleaning cadre. It is strictly prohibited to touch the charging core with hands when it is powered.

	WARNING: It is strictly prohibited to use the charger when the nozzle or charging cable is defective, cracked, worn, and the nozzle line is exposed. If any, please contact the staff in time.
	WARNING: In case of rain and thunder, please use electricity carefully. It is better to stop charging.
	WARNING: Do not attempt to disassemble, repair or modify the charger. For repairs or modifications, please contact the staff. Improper operation may result in damage, water leakage, electricity leakage, etc.
	WARNING: It is forbidden to insert and unplug the plug during the charging process to ensure the safety of life and the vehicle during the charging process.
	WARNING: It is strictly prohibited to continue to use this product for charging in case of failure.
	WARNING: If any leakage or insulation failure occurs during the operation of the product, please press the emergency power off button immediately.
	WARNING: Obvious maintenance marks shall be set up. Isolation and protection measures shall be added to live parts that may be near by operators to avoid contact.

CAUTIONS

	CAUTION: Wrong installation and testing of the charger will cause potential damage to the vehicle battery, assembly, and the charger itself.
	CAUTION: To reduce the risk of fire, connect only to a circuit provided with 100 amperes maximum branch circuit overcurrent protection in accordance with the National Electrical Code, ANSI/NFPA 70 and the Canadian Electrical Code, Part I, C22.1.
	CAUTION: Do not operate the charger in temperatures outside its operating range of -35°C to + 55°C.

NOTE:

Electrical equipment should only be installed, operated, serviced, and maintained by qualified personnel. No responsibility is assumed by our company for any consequences arising out of the use of this material.

A qualified person is one who has skills and knowledge related to the construction, installation, and operation of electrical equipment and has received safety training to recognize and avoid the hazards involved.

2. Technical Specifications

Model	ATPIII 6507W	ATPIII 6511W	ATPIII 6521W
Charging Type	Charging Mode 3 Case B & Case C		
Outlet Options	AC Type 2 (IEC 62196-2)		
Input/ Output Current rating	32A, single phase	16A, three phase	32A, three phase
Input/ Output Power rating	Up to 7.7 kW	Up to 11.5 kW	Up to 23 kW
Input/ Output voltage	220-240VAC	380-415VAC	380-415VAC
Input Frequency	50 Hz or 60 Hz		
Number of EV Served	Up to 1		
Cable Length	5.0 m, Optional: 7.5m		
Distribution Systems	TT, TN		
Connector Type	1P + N + PE	3P + N + PE	3P + N + PE
Protection	Overcurrent, overvoltage, undervoltage, ground fault, RDC(TypeA+DC6mA), Over-temperature protection		
Overvoltage Category	Type III		
Energy Metering	NO		
Cellular Communication	NO		
User in interface			
Connectivity	WIFI/Bluetooth		
User Authentication	Plug & Play /APP		
Status Indication	Colored status indicator		
RFID Reader	Optional		
Emergency Button	NO		
Configuration			
Software Upgrade	Over-the-air (OTA)		
Language System	English, Chinese		
General characteristics			
Protection Rating	IP65 and IK10 (Enclosure)		
Housing Material	Plastic PC		
Operational Altitude	Up to 2000 m		
Operating Temperature	-35 °C to +50 °C		
Starage Temperature	-40 °C to +80 °C		
Humidity	< 95%, non-condensing		
Mounting	Wall-mount or pedestal stand		
Dimensions (D x W x H) mm	80×197×286		

Net Weight (kgs)	3.13	4.02
Compliance Standards		
Codes and Standards	IEC 61851-21-2, EN 61000-6-1, EN 61000-6-2, EN 61000-6-3, EN 61000-6-4, EN 61000-3-11, EN 61000-3-12, IEC 61008-1, IEC 61008-2-1, EN 62423, IEC 62196-1, IEC 62196-2	
Safety Standards	IEC 61851-1 , IEC 61851-21-2, IEC 62196-1, IEC 62196-2	

*Product specifications are subject to change without further notice

3. Introduction

The AC EV charger comes with a charging plug. The maximum output power of 23kw, with 99% efficiency. For ease of operation, the electric vehicle charger is equipped with a mobile app, which conveniently and quickly meets the needs of home charging.

3.1. Product Overview

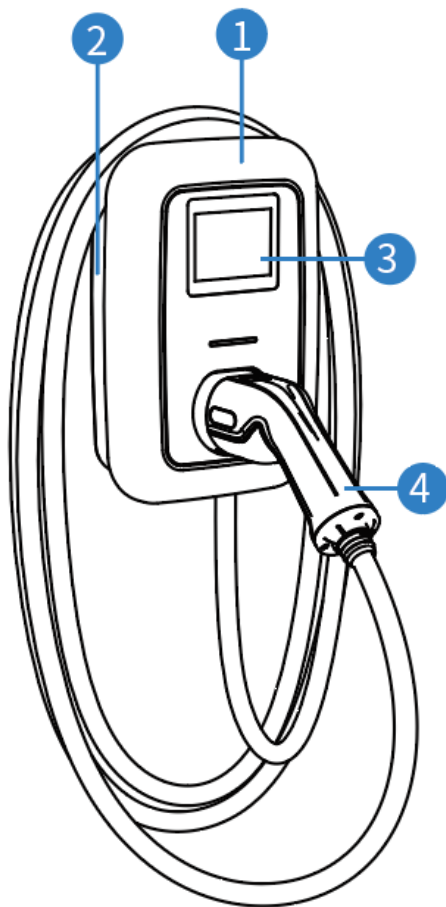

- 1 External Cover
Detachable; locked onto the base cover.
- 2 Base Cover
To protect the printed circuit board (PCB).
- 3 LED display
Display the operating status of the charging station
- 4 Nozzle
Insert the nozzle into the vehicle charging port for charging

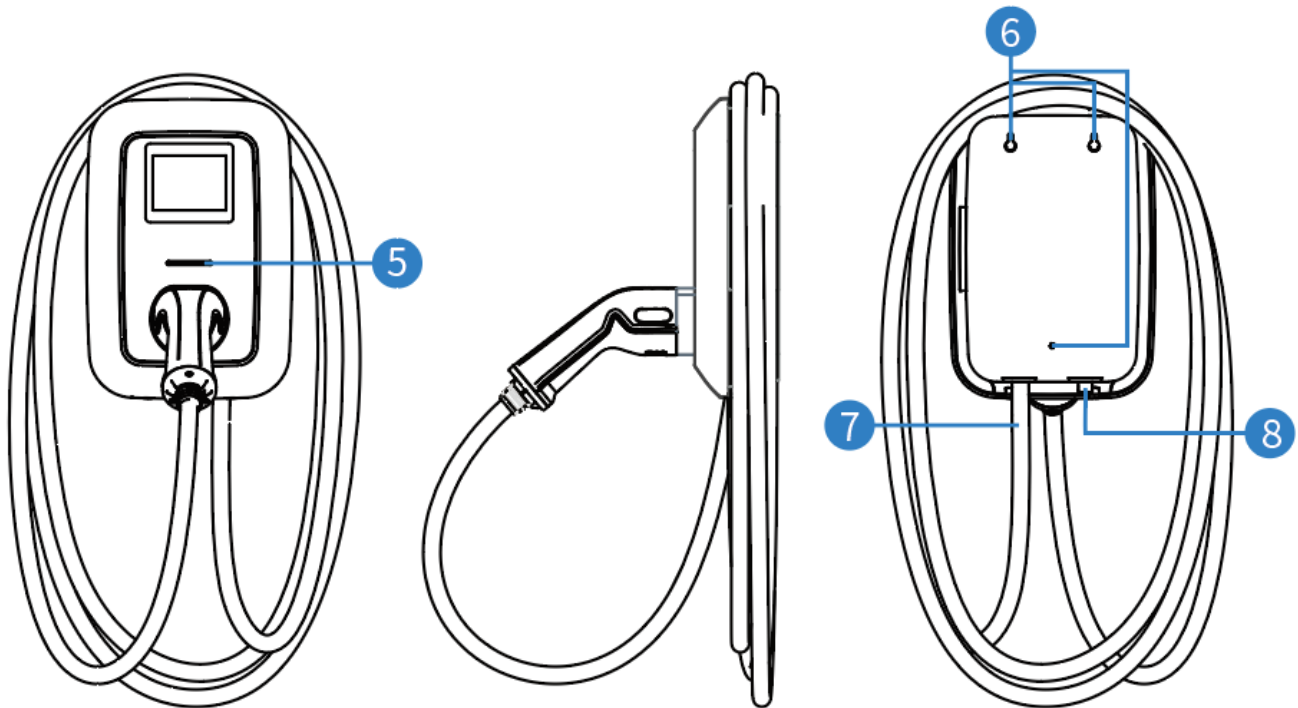



5 LED pilot lamp



Idle

Charging

Fault

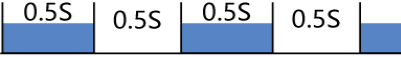
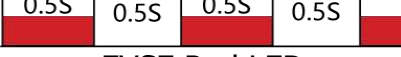
State	Description	LED Light Status (Regulation)
State A	(Idle)	 EV Green LED
State B	Vehicle Connected	 EV Blue LED
State C	Charging	 EV Blue LED
State F	Fault	 EVSE Red LED

- 6 Mounting Holes
To fix the charger on the wall after inserting screws.
- 7 Charging Cable Hole
For charging connector.
- 8 Incoming Cable Hole
For incoming cable.

3.2. Dimensioned Drawing

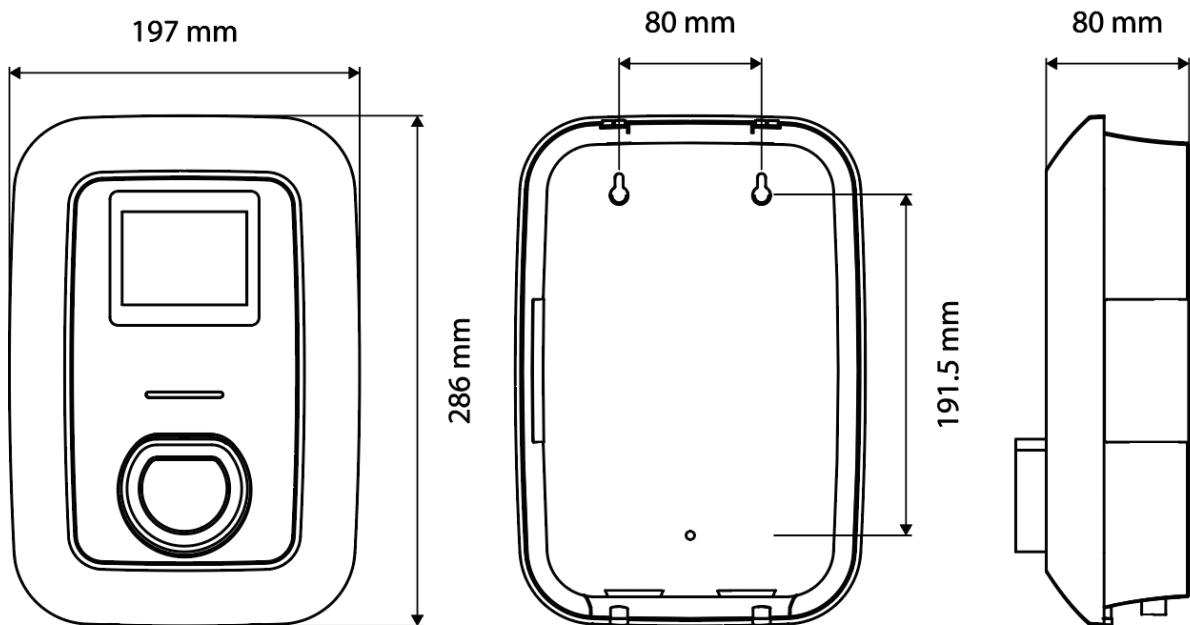

4. Packaging

The charger is delivered in a carton packaging. The following figure shows the packaging for the charger.

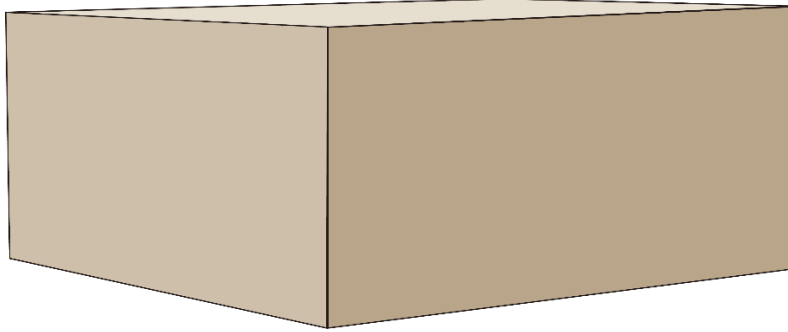

NOTE: The charger must be stored in its original packaging in a dry environment between $-40\text{ }^{\circ}\text{C}$ to $+80\text{ }^{\circ}\text{C}$.

It is recommended to ship the charger to its final destination in its original packaging and unpack it there.

5. Installation

5.1. Pre-Installation

	<ul style="list-style-type: none">● Danger to life due to improper installation!● Ignoring environmental conditions when handling electricity can lead to hazardous situations.
---	--

Before performing any installation activities, carefully read each item listed in this chapter that is critical to the installation process.

[Location Selection]

Consider before choosing where to install:

1. Meets all criteria regarding charger placement and location.
2. Make sure the installation location complies with cellular signal strength standards.
3. Avoid use in offshore environments or land-based outdoor environments near strong pollution sources and in environments with simple shelter. Otherwise, it is easy to lead to corrosion of the product, water ingress and other problems caused by module failure, resulting in abnormal functions or component damage is not covered by the warranty. A source of contamination is defined as an area within the following radius:
 - 0.5 km away from salt water (e.g. ocean).
 - 3 km away from heavy pollution sources such as metallurgy, coal mines, and thermal power plants.
 - 2 km away from medium pollution sources such as chemical, rubber, electroplating, etc.
 - 1 km away from light pollution sources such as food, leather, heating pots, etc.
4. For offshore applications, there may be pitted rust of the module shell or shortened life of the whole machine, which needs to be carefully selected, please consult the relevant service department for details. The offshore range value is within the following radius: 0.5 km ~ 3.7 km from salt water (such as ocean).
5. The installation environment shall meet the environmental characteristics specified in the technical data.

[Local Conditions]

1. Area is dry and well ventilated.
2. The area is not exposed to dust, high temperatures, explosive gases, flammable materials or corrosive fumes.
3. Wiring and conduit needed to connect the charger to the board.
4. The location of the charging port when the vehicle is parked.
5. Space clearance requires minimum dimensions for airflow and service channels.

[Input power distribution installation suggestions]

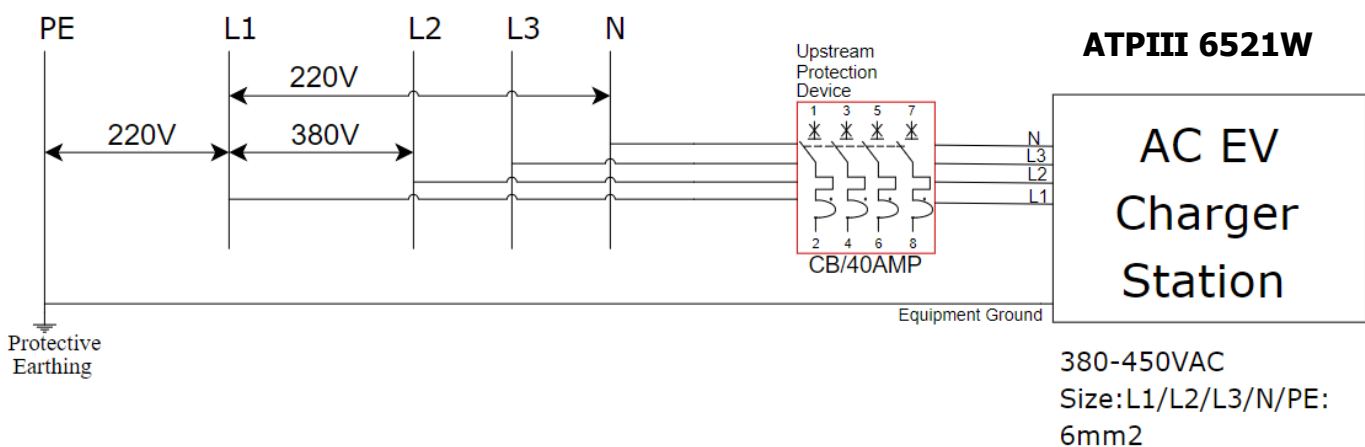
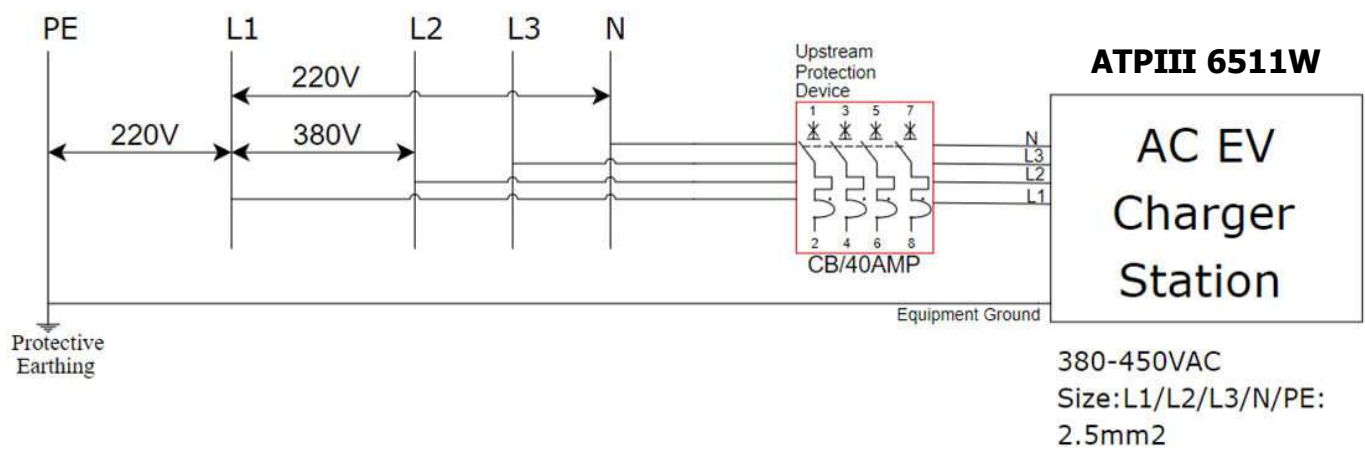
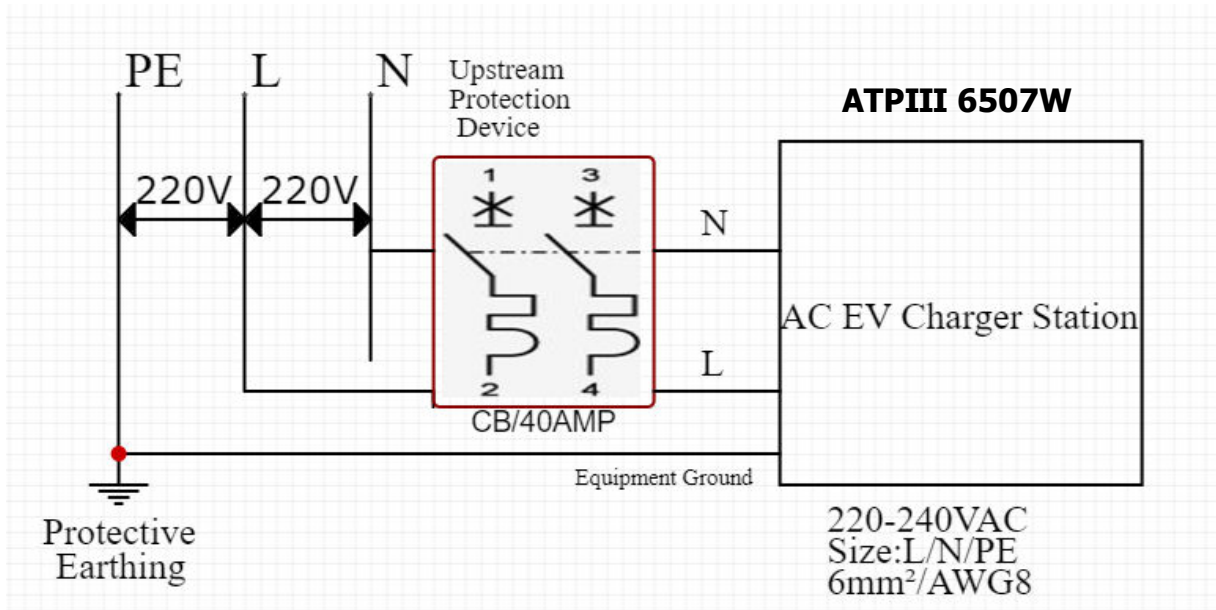

- Please configure CB (Circuit-breakers) before installation
- **The recommended specifications of Circuit-breakers and Type B RCCB are shown in the following table:**

Model	Component	Value / rating	Standard
ATPIII 6507W	Circuit-breakers with overcurrent protection	Ue= 400V~(1P+N); 50/60Hz, In=40A,	IEC/EN 60898
ATPIII 6511W	Circuit-breakers with overcurrent protection	Ue= 415V~(3P+N); 50/60Hz, In=40A,	IEC/EN 60898-1
ATPIII 6521W	Circuit-breakers with overcurrent protection	Ue= 415V~(3P+N); 50/60Hz, In=40A,	IEC/EN 60898-1

NOTE:

- The 2-PIN are recommended for Circuit breakers.

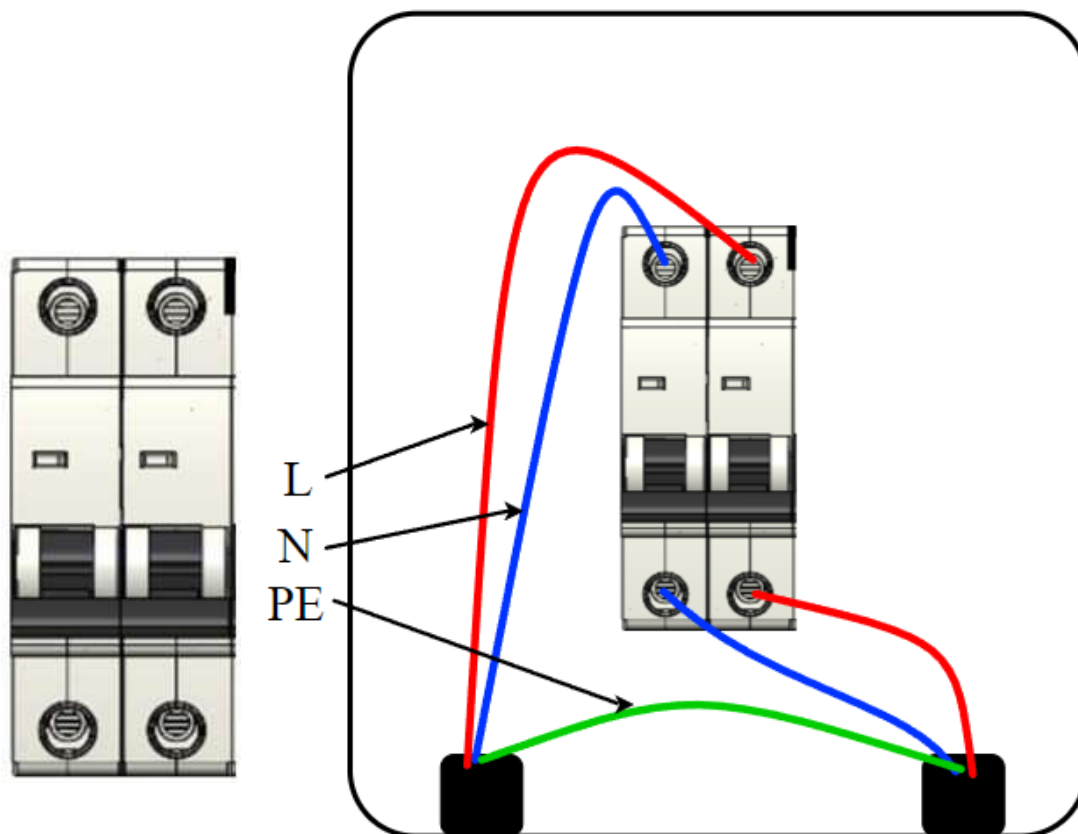

- The 4-PIN are recommended for Circuit-breakers.

- Before installing the charging station, you need to configure the wire box and then connect the wires.

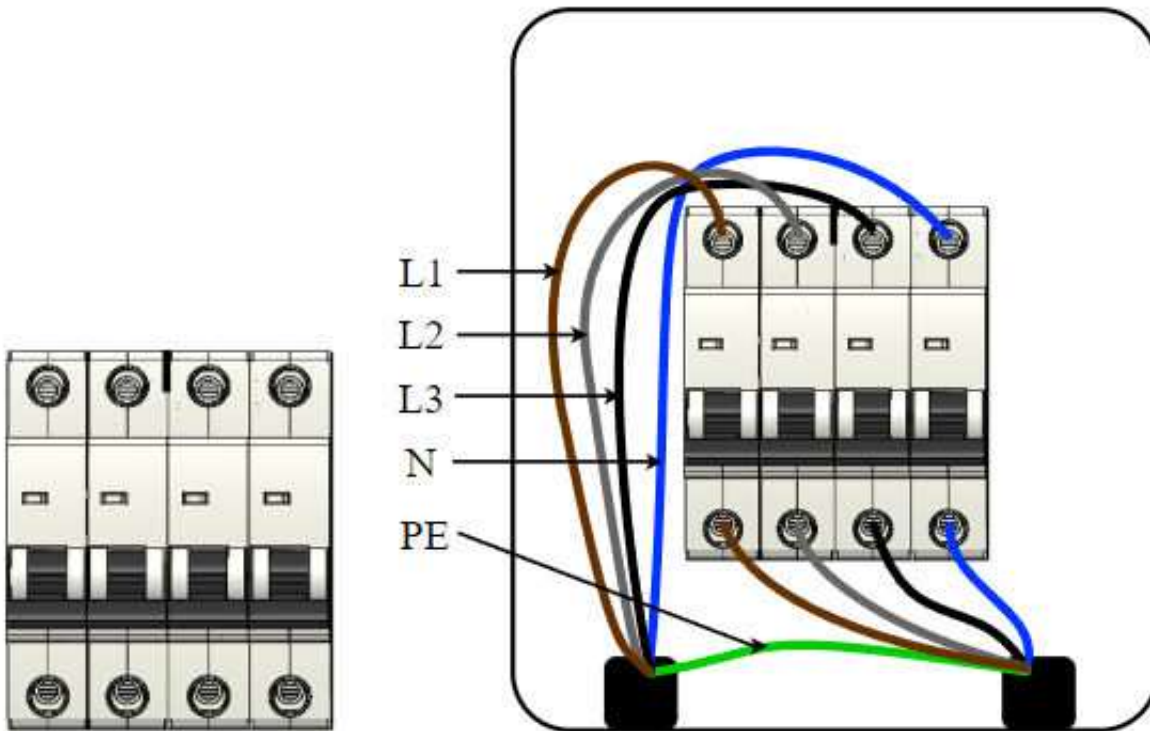

 **Warning:** Before using this type of charging pile, Circuit-breakers with similar standard certification parameters must be configured, if you do not configure the Circuit-breakers and RCCB that meet the certification parameters of similar standards, you will bear the dangerous consequences!

5.2. Cable Reach

In the default configuration, the Charging station comes with a cable length of 500cm. Figure 5.1 below shows the Charging station's operating radius (5m).

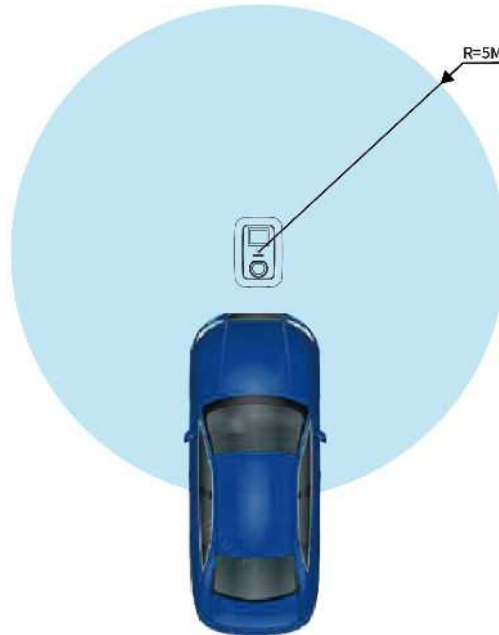

Figure 5.2

5.3. Construct Foundation

- The Charger Pedestal can be built on a concrete foundation, the flat surface of the foundation should not be less than the dimension of 400 mm * 400 mm.
- When preparing the foundation base and cabling pay regard to positions of cable through holes and expansion bolts, which was dimensioned in Figures 5.3.1 & 5.3.2

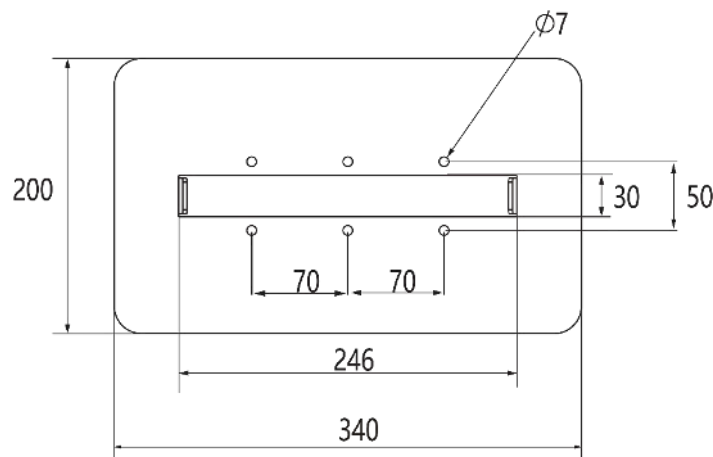

Figure 5.3.1 Construct Foundation for Pedestal Charger

The height of the foundation is determined by the topography and natural environment of the site. Depending on rainfall and drainage, a height of between 15 cm and 30 cm above the ground is recommended. The foundation must be about 80 cm deep in the ground due to frost protection.

NOTE:

- The unit must be mounted on solid and flat stone slabs or walls.
- Different types of slate require expansion bolts, or choose appropriate screws for installation, and in some cases drill holes.
- The laying of power cables shall comply with relevant national and industry standards and specifications.
- The cable selection specification should be selected according to the number of equipment and the type, power, voltage and current level of the installed equipment.
- When laying the cable, it is strictly forbidden to expose it.
- When the cable is buried directly, the buried depth should not be less than 0.8m to prevent freezing.
- The selection of power cable specifications should be selected according to the installation environment and fire protection requirements.

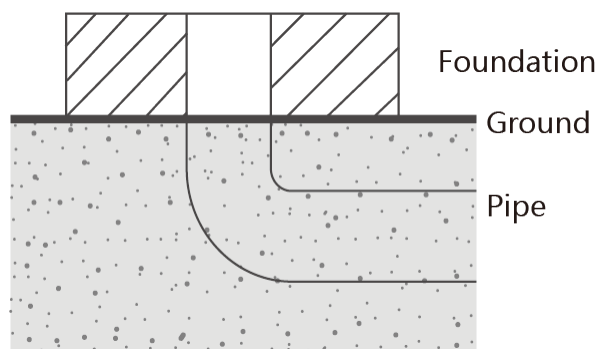
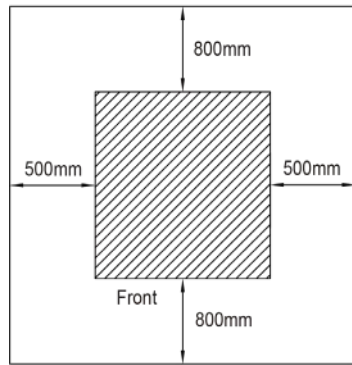

Figure 5.3.2

5.4. Space Requirement

When installing the charger, make sure to keep a minimum distance from objects that may be around the charger to allow for adequate airflow, and secondly, to leave room for possible repair or operations.

The following diagram shows the recommended minimum distances during on-site installation:



Top view

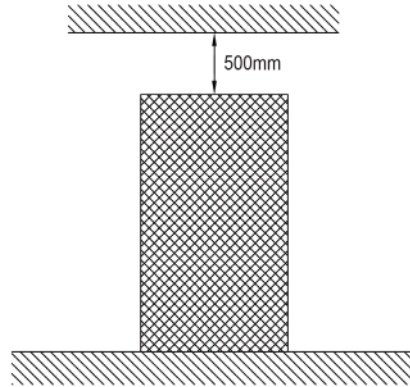

Front view

Figure 5.4 Clearance dimensions for Pedestal Charger

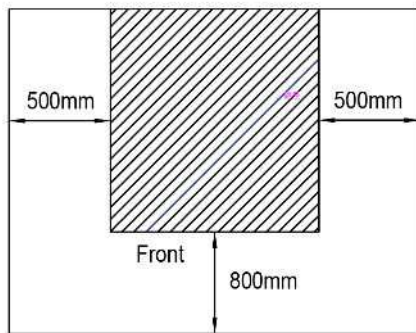

Top view

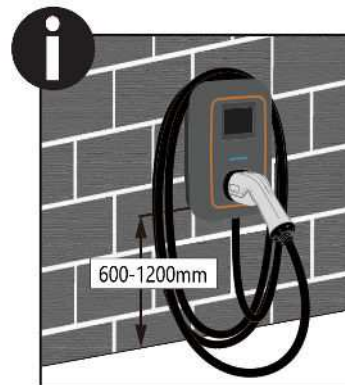

Figure 5.4 Clearance dimensions for Wall-Mount Charger

NOTE: Clearance dimensions are published for airflow and service access only. Consult your local safety regulations and standards for other requirements in your local area.

5.5. Single Pedestal Installation

Step 1 : The pedestal base installation

1. Mark the installation position on the stone slab with the pedestal base and leveling tool, and apply bolt stud.
2. Align the holes on the pedestal base with the four stud bolts on the stone slab and fix them with four M5 nuts.

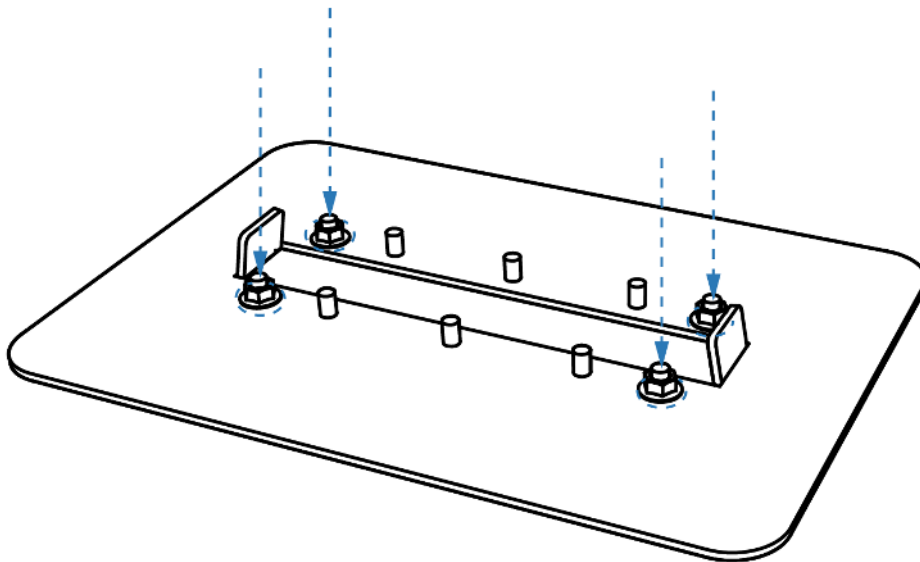

Step 2 : Fix pedestal to ground

Align the bottom of the charger pedestal with the screws on the mounting plate and fasten them with six M5 nuts.

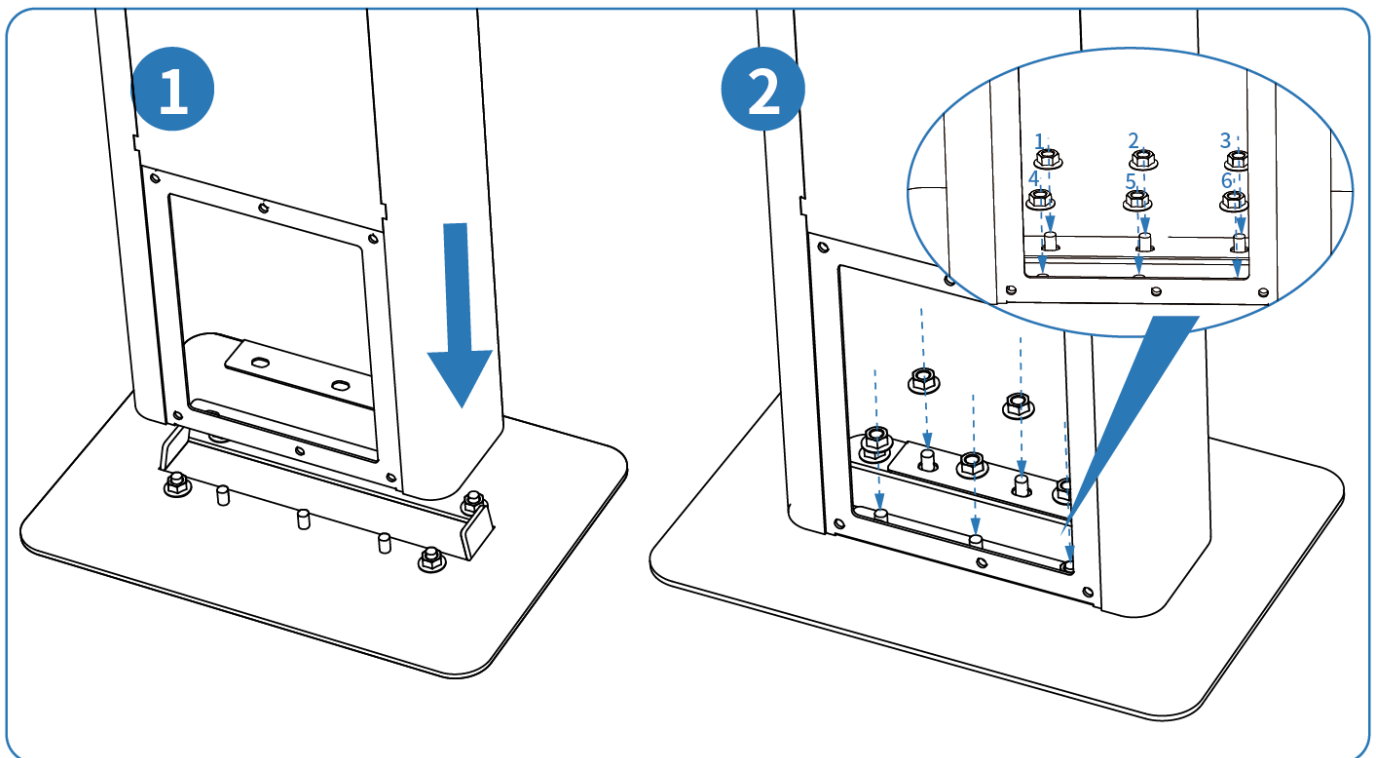

Step 3 : Close the panel of the pedestal and tighten it with six M5 screws

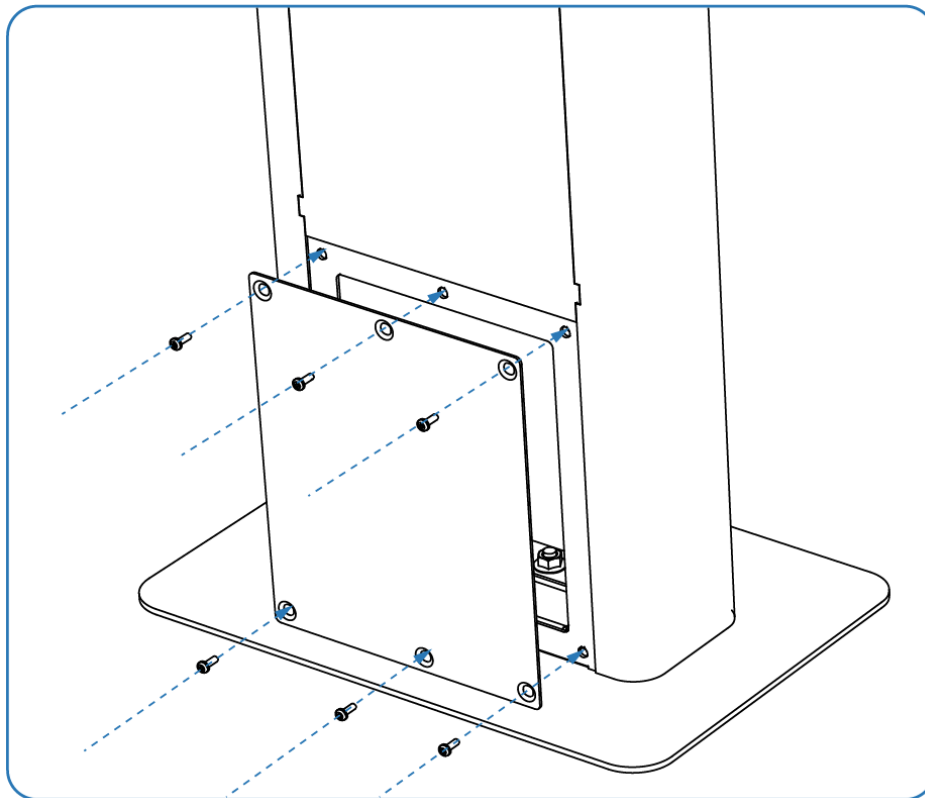

Step 4 : The upper part of the pedestal installation

1. Place the middle baffle on the inner base plate of the upper part of the pedestal.
2. Place the upper part of the column into the corresponding screw hole of the lower part, and fasten it with eight M5 nuts.

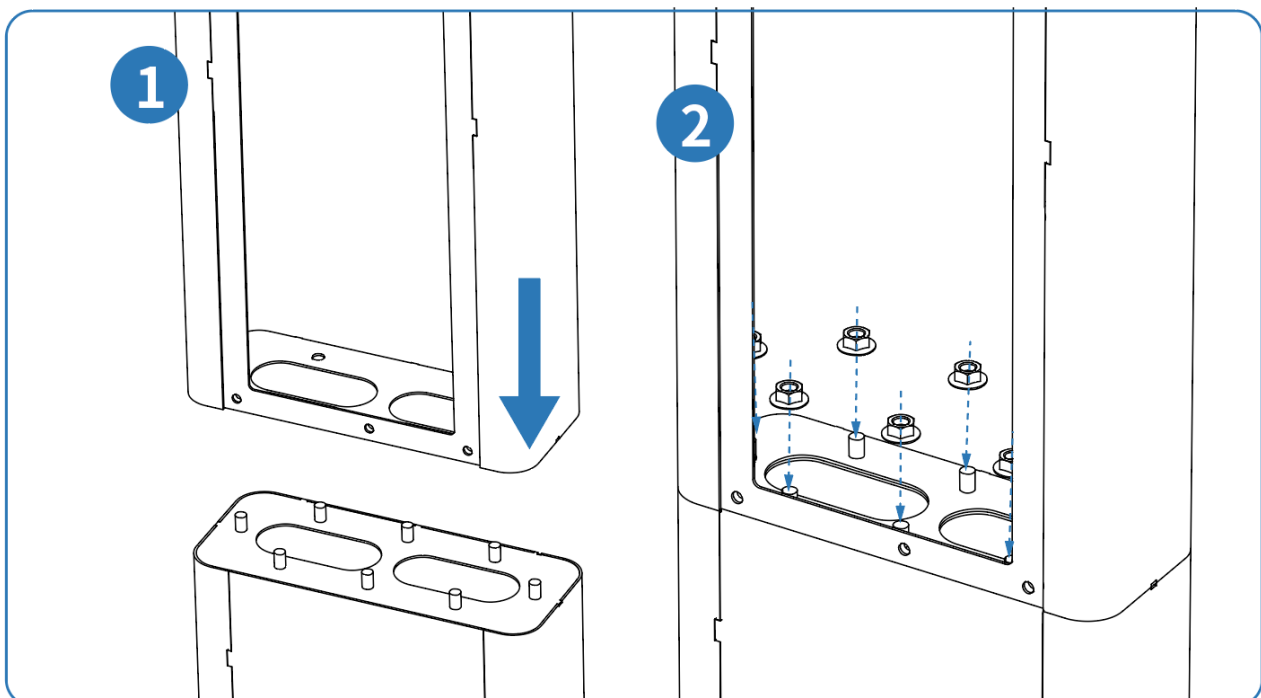

Step 5 : Close the upper part of pedestal and tighten it with six M5 screws

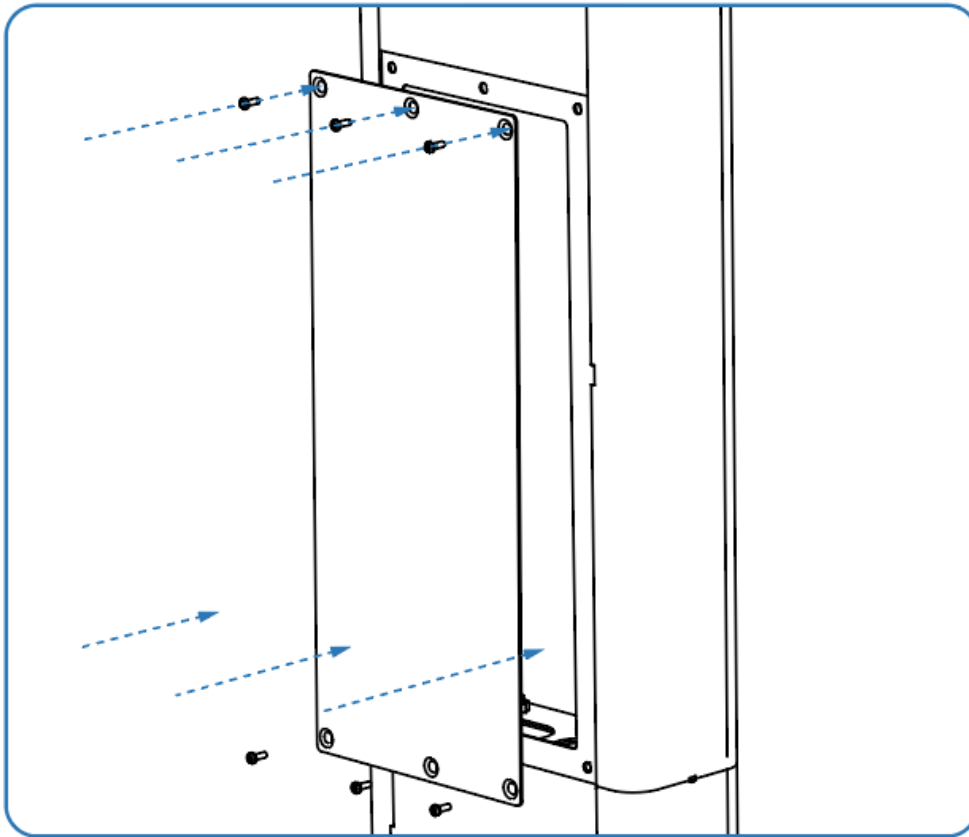

5.6. AC Charger Installation

Step 1 : Opening the external cover.

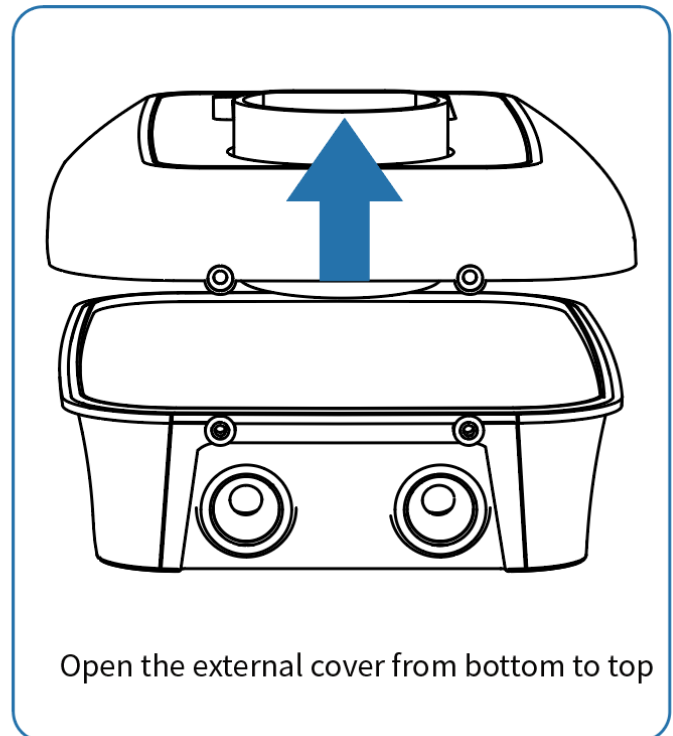
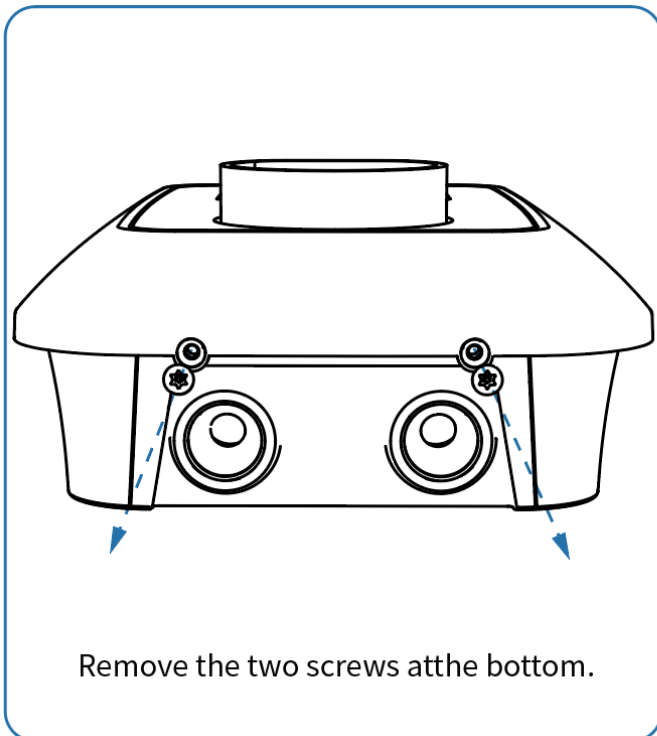

Step 2: Insert the two M4x32 screws

1. Find the upper two holes on the pedestal.
2. Insert the two M4x32 screws into the holes, allowing the heads of the screws to protrude by at least 5 mm.

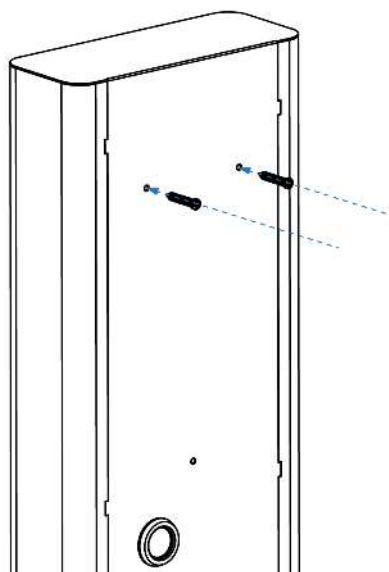

Step 3: Install the rear cover and nozzle bracket

1. Hang the AC EV charger onto the two top screws that have been installed.
2. Secure the washer and third screw to the bottom hole..

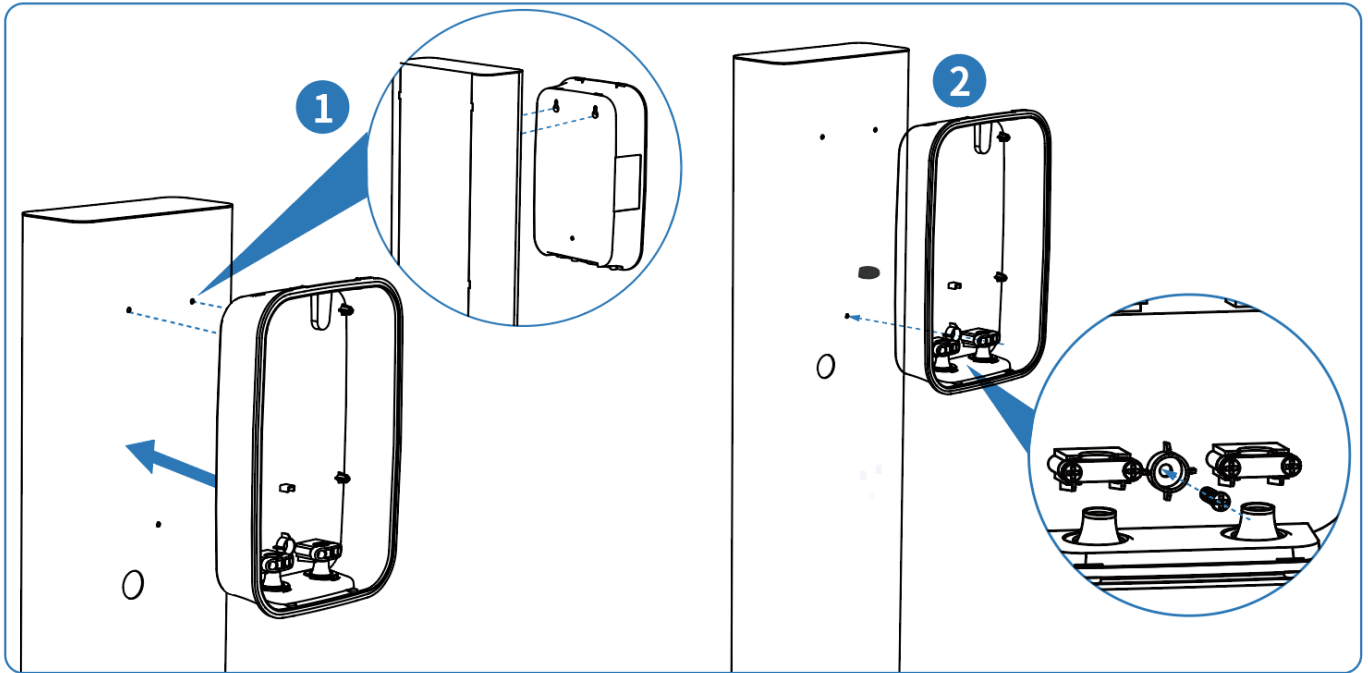

Step 4: AC Wiring

Install two main (L1, N), and ground wires.

1. Remove a length of 40mm of the cable jacket and strip the wire insulation to a length of 8~15mm.
2. Fix the wire through the outlet on the crimping clip and tighten the two screws at the crimping clip.
3. Crimp the terminals as shown in the figure below, insert the wire into the corresponding wire slot.

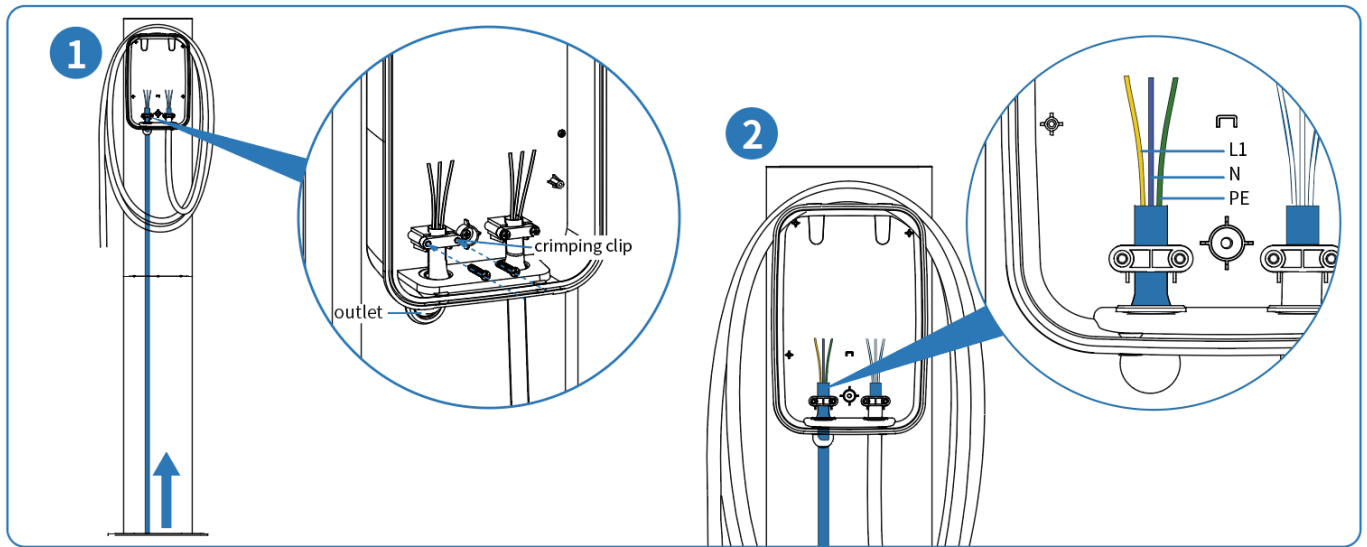

Caution: Follow all local electric codes when wiring this EV Charger

	ATP3 7kw			ATP3 11kw			ATP3 21kw		
	L	N	GND	L1/L2/L3	N	GND	L1/L2/L3	N	GND
Recommended Wire Gauge*	8AWG-10AMG	8AWG-10AMG	8AWG-10AMG	11AWG-13AWG	11AWG-13AWG	11AWG-13AWG	8AWG-10AMG	8AWG-10AMG	8AWG-10AMG
Recommended Lug	NO	NO	NO	NO	NO	NO	NO	NO	NO
Wire Type	Copper	Copper	Copper	Copper	Copper	Copper	Copper	Copper	Copper
Screw Type	NO	NO	NO	NO	NO	NO	NO	NO	NO
Torque (lbf-in)	13.28	13.28	13.28	13.28	13.28	13.28	16.5	16.5	16.5

Step 5: Close the external cover

1. Press the external cover tightly onto the back cover
2. Tighten the two screws at the bottom of the external cover.

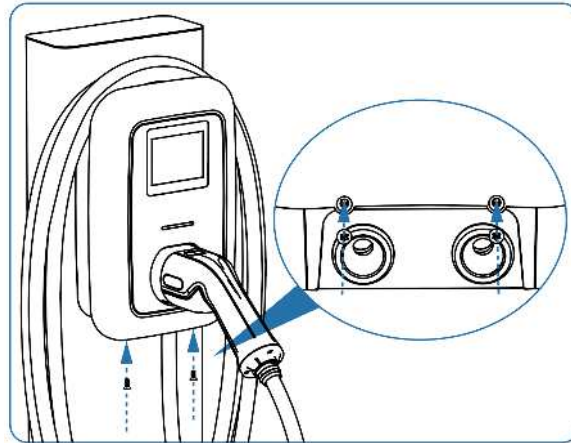

5.7. Back to Back Pedestal Installation

The installation method of back to back pedestal is the same as that for single pedestal. You can refer to the installation method of single pedestal.

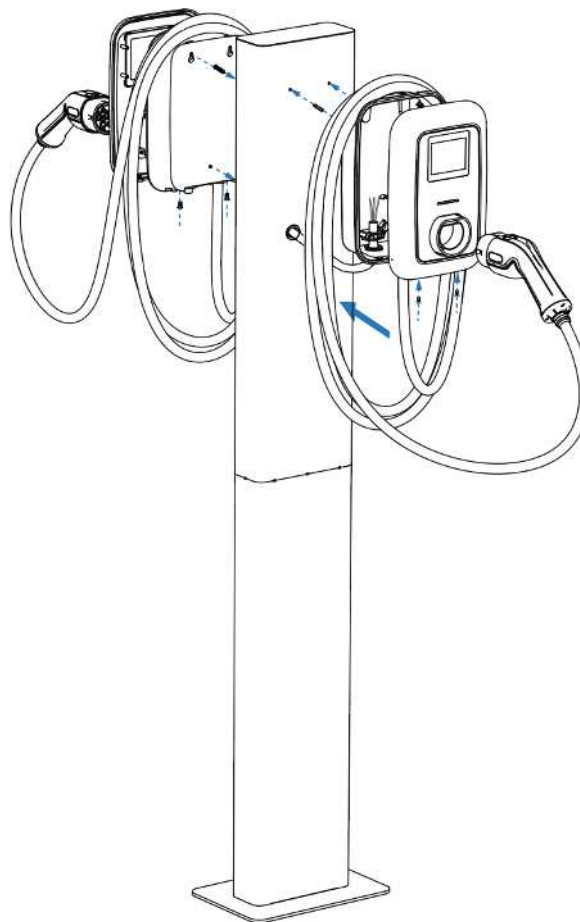

5.8. Wall-Mount Charger Installation

Step 1 : Opening the external cover.

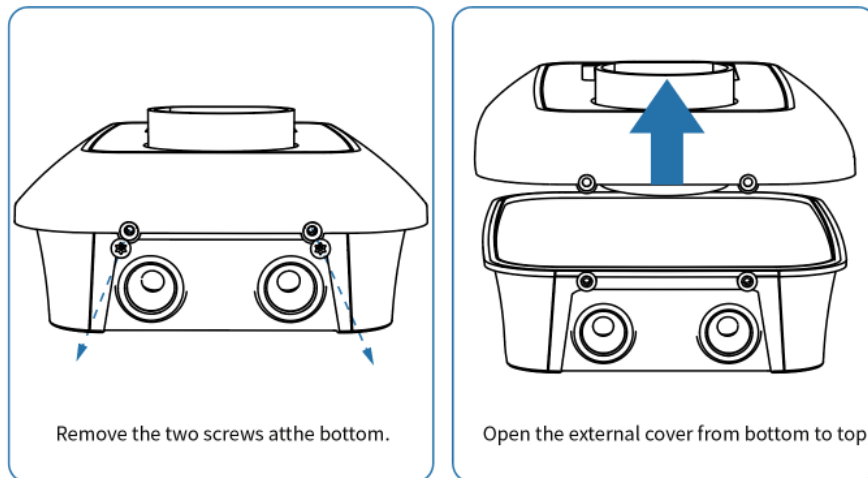

Step 2: Mounting rear cover

1. Based on the installation position template, identify the installation position and mark the two holes for the wall screws, which will be inserted in the top rear of the charger.

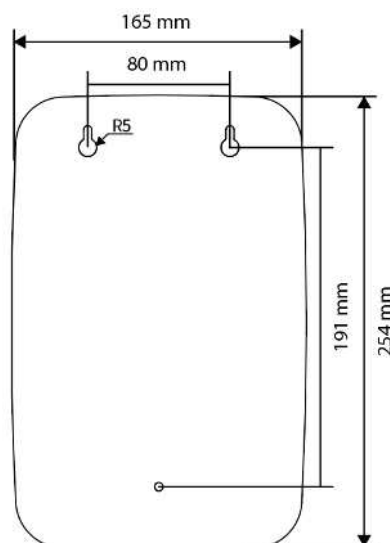

2. Drill two holes with the 5mm diameter drill bit and insert the expansion bolts horizontally into the holes, paying attention to the force and depth with which they are inserted (make sure the plug completely enters the hole).
3. Insert the two M4 screws into the wall plugs, allowing the heads of the screws to protrude by at least 5 mm.

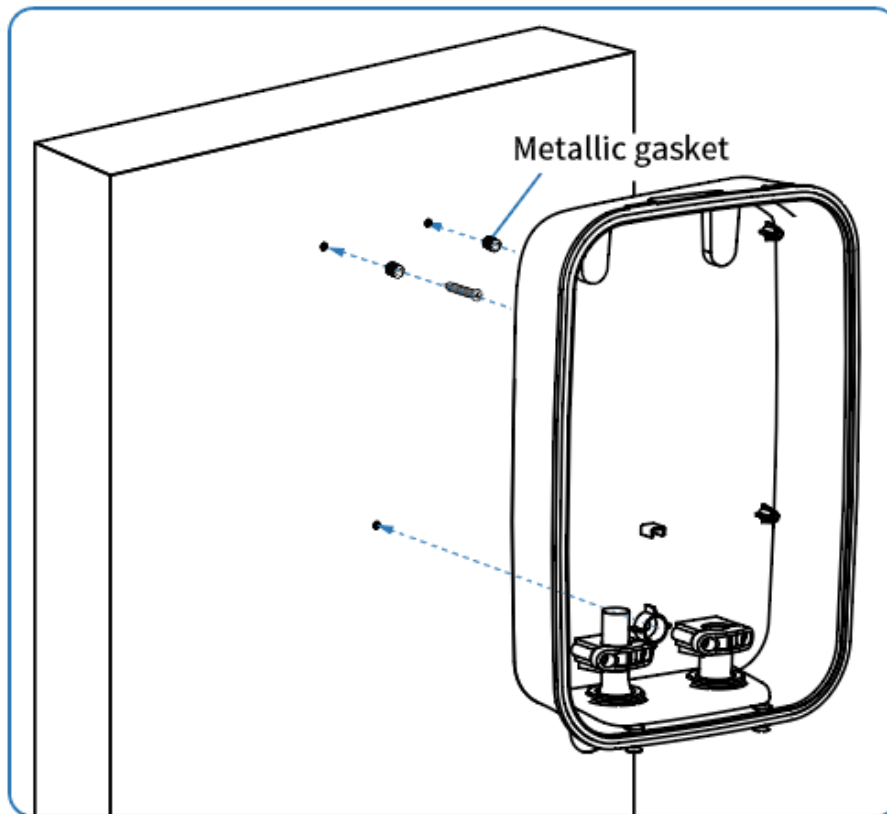

4. Mark the position of the third fastening screw. The hole is located at the bottom of the charger.

5. Insert the washer and expansion bolt into the third hole and secure the third screw.

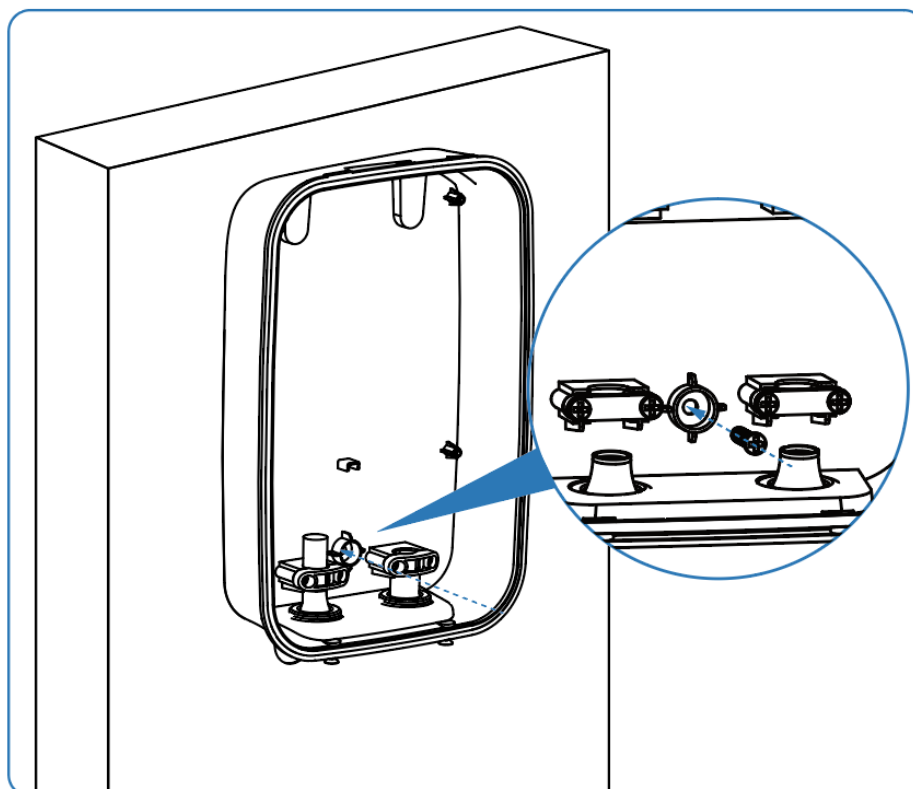

Step 3: AC Wiring

1. Remove a length of 40mm of the cable jacket and strip the wire insulation to a length of 8~15mm.
2. Fix the wire through the outlet on the crimping clip and tighten the two screws at the crimping clip.
3. Crimp the terminals as shown in the figure below, insert the wire into the corresponding wire slot.

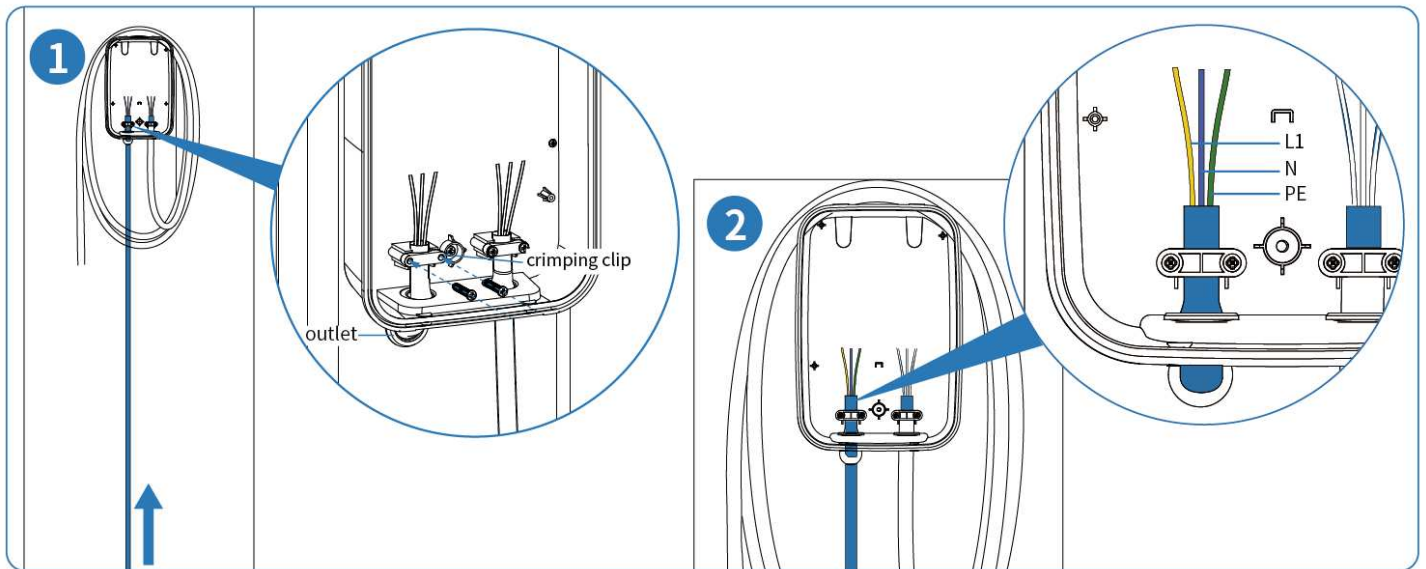

Caution: Follow all local electric codes when wiring this EV Charger

	ATP3 7kw			ATP3 11kw			ATP3 21kw		
	L	N	GND	L1/L2/L3	N	GND	L1/L2/L3	N	GND
Recommended Wire Gauge*	8AWG-10AMG	8AWG-10AMG	8AWG-10AMG	11AWG-13AWG	11AWG-13AWG	11AWG-13AWG	8AWG-10AMG	8AWG-10AMG	8AWG-10AMG
Recommended Lug	NO	NO	NO	NO	NO	NO	NO	NO	NO
Wire Type	Copper	Copper	Copper	Copper	Copper	Copper	Copper	Copper	Copper
Screw Type	NO	NO	NO	NO	NO	NO	NO	NO	NO
Torque (lbf-in)	13.28	13.28	13.28	13.28	13.28	13.28	16.5	16.5	16.5

Step 4: Close the external cover

1. Press the external cover tightly onto the back cover
2. Tighten the two screws at the bottom of the external cover.

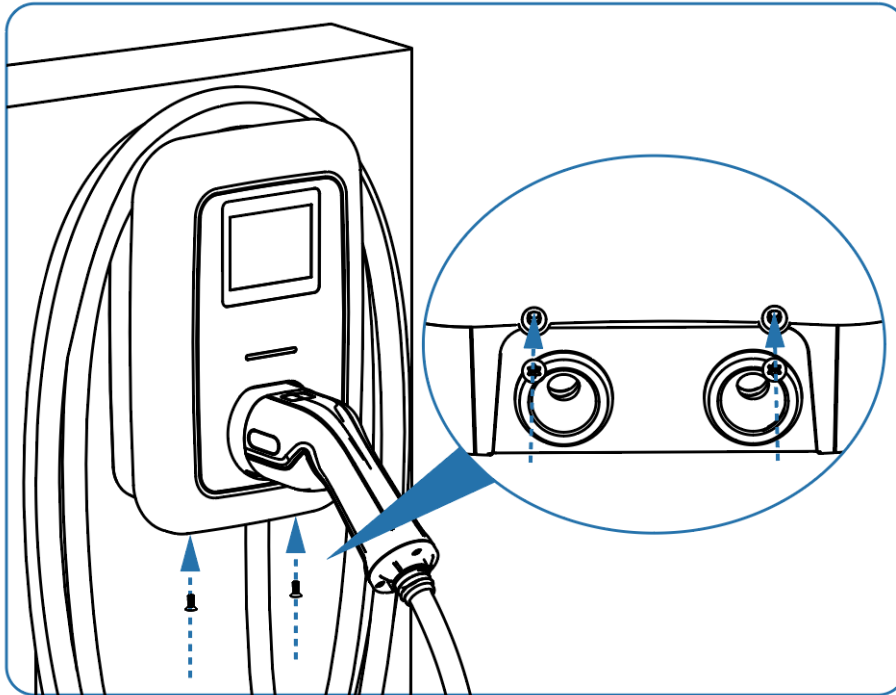

6. Mobil Uygulama Kullanım ve Kurulum Kılavuzu

6.1 Kayıt ve giriş

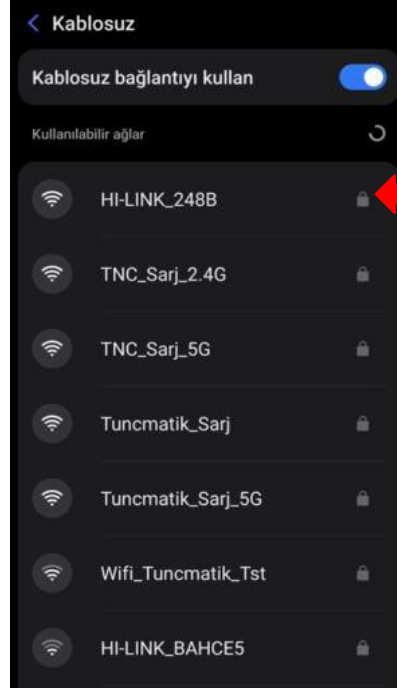
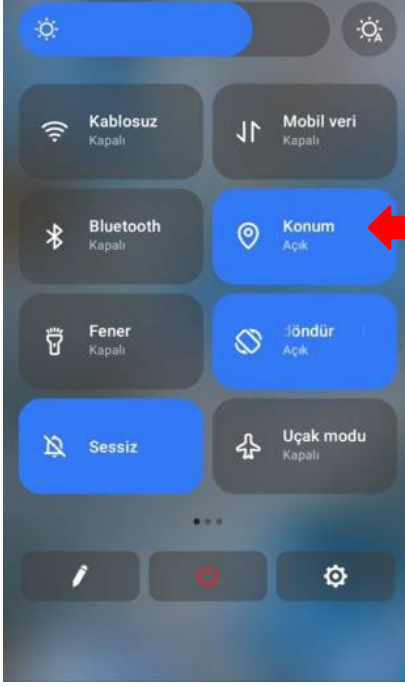

1. ADIM: Uygulamayı açmadan ve cihazınıza bağlanmadan önce KONUM servisini açın.

KONUM servisinin açılması uygulama içerisinde bağlantı sağlar iken etrafınızda bulunan Wi-Fi noktalarını gösterilmesini sağlar.

2. ADIM: Wi-Fi arama kısmından cihazınızın Wi-Fi kullanıcı adını HI-LINK olarak başlayan addan bulabilirsiniz.

Örnekte de görüldüğü gibi test cihazın Wi-Fi adı HI- LINK_248B.

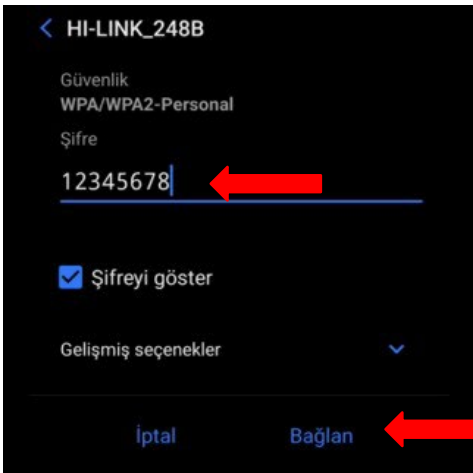

3. ADIM: Cihazınızın Wi-Fi şifresi resimdeki gibidir. Şifrenizi yazdıktan sonra BAĞLAN yerine basın.

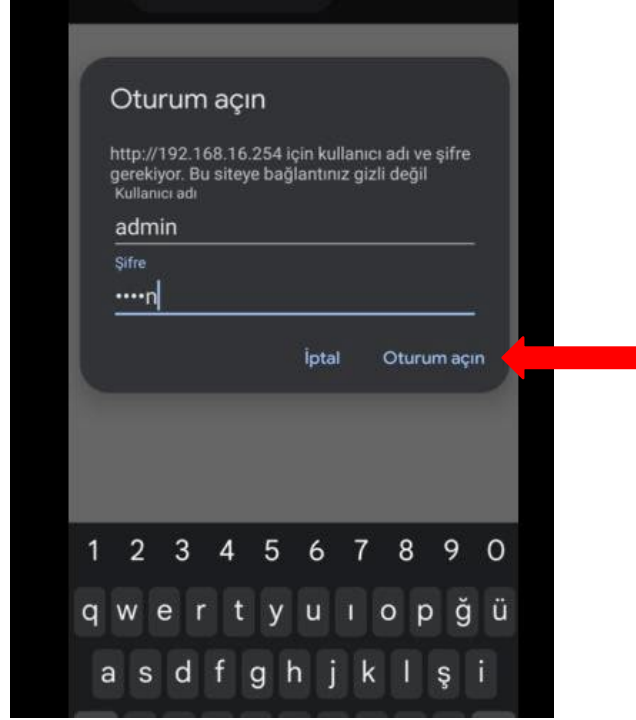
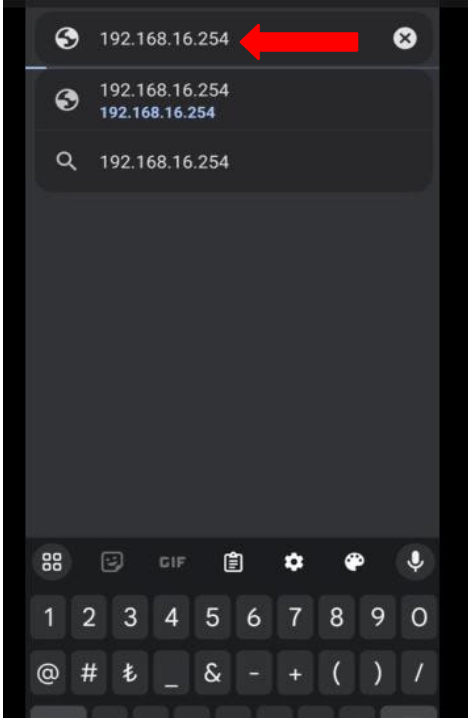

4. ADIM: Telefonunuzun internet arama motorundan yukarıda yazılan numarayı girmeniz gerekecek.

5. ADIM: Kullanıcı adı ve şifre admin. Ardından Oturum açına basın.

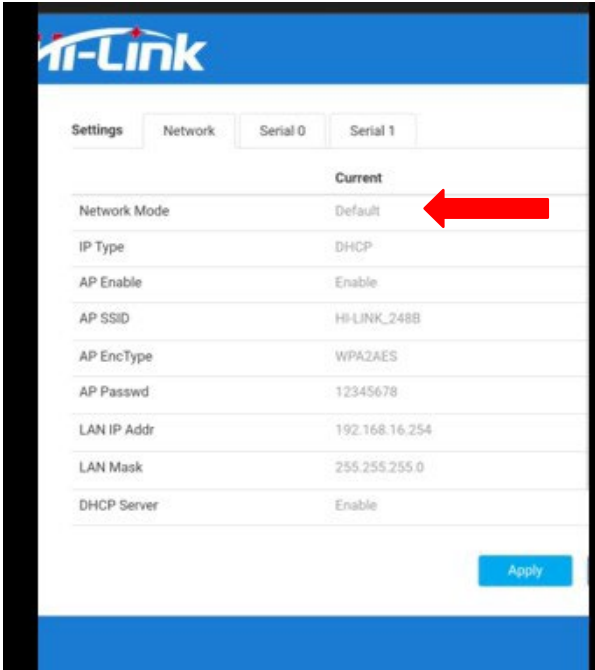

6. ADIM: Oklar ile gösterilen yerlerdeki bilgiler değiştirilecek. İlk olarak Network Mode kısmının değişikliğini yapacağız.

UYARI: Eğer Network Mode göstergeniz AP CLIENT ve STA EncType değeri WPA2AES ise bu kısımları geçebilirsiniz.

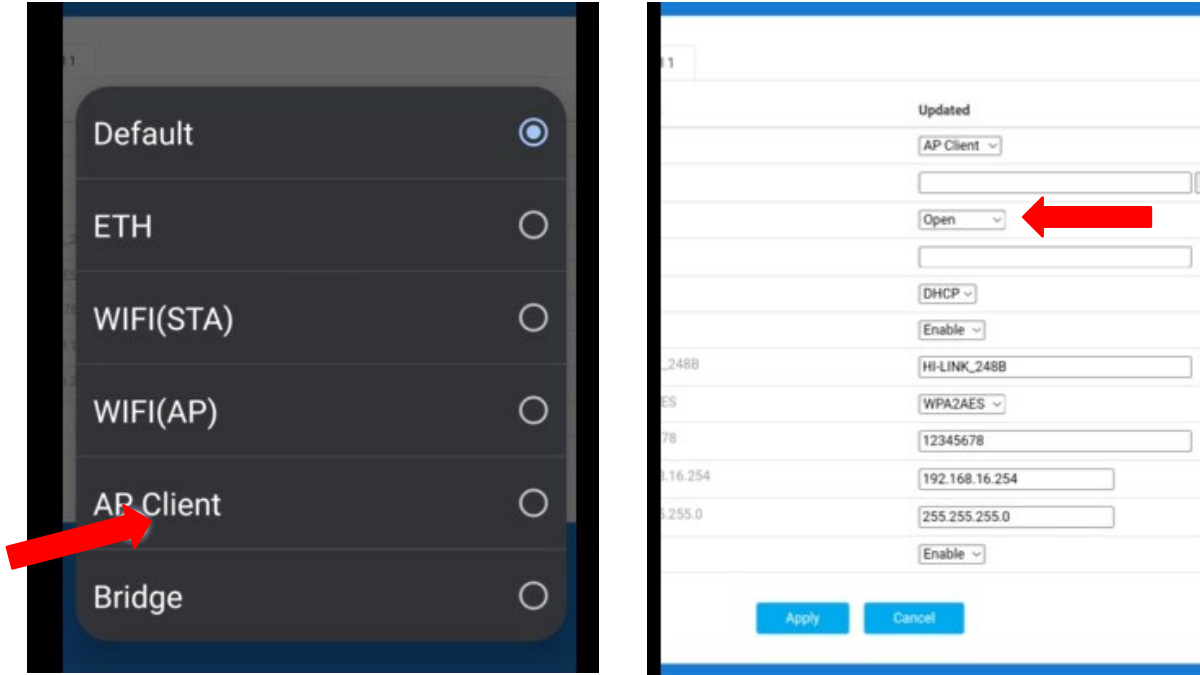

7. ADIM: Default dan AP Client kısmına geçiyoruz.

8. ADIM: Network Mode değişiklik yapınca STA EncType kısmı açılacak. Ardından OK ile gösterilen yere tıklayıp değişiklik yapacağız.

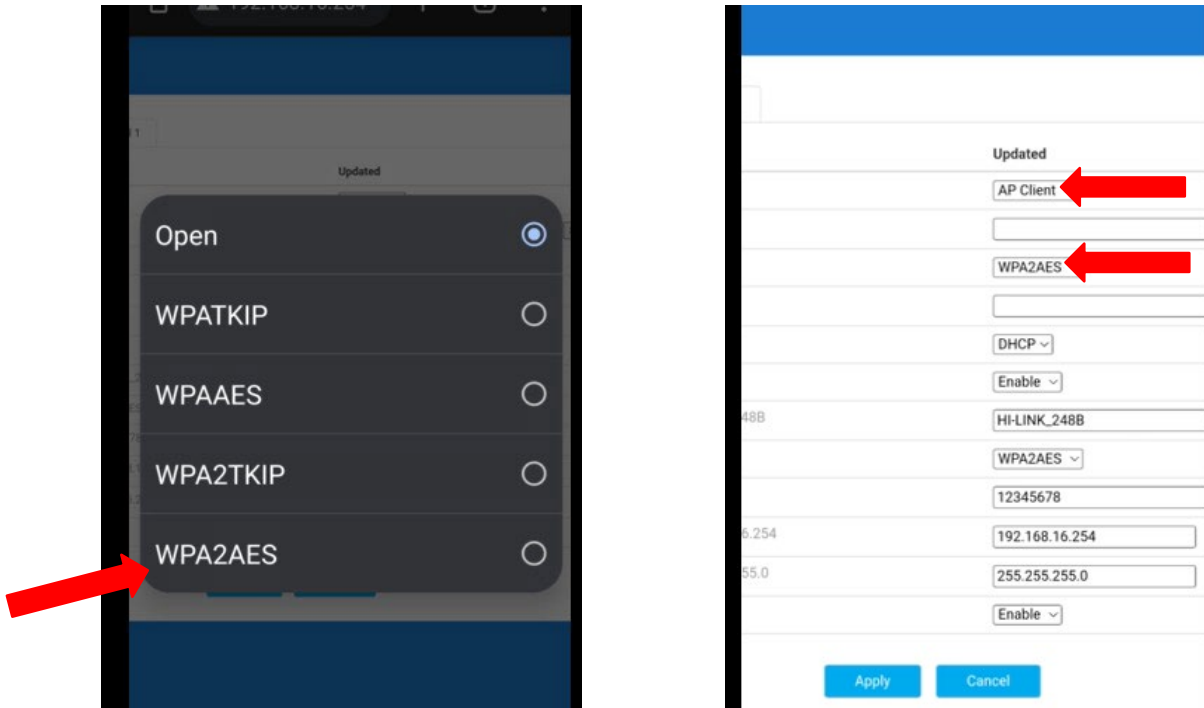

9. ADIM: STA EncType için Open dan WPA2AES kısmına geçiyoruz.

ADIM: Ardından onayladıktan sonra ana sayfada APPLY butonuna basıp 20 SANİYE bekliyoruz.

10. ADIM: Ok ile gösterilen değiştirdiğimiz yerleri

kontrol edelim. Resimdeki gibi değişiklikler yapıldıysa T- CHARGER uygulamasını açabiliriz.

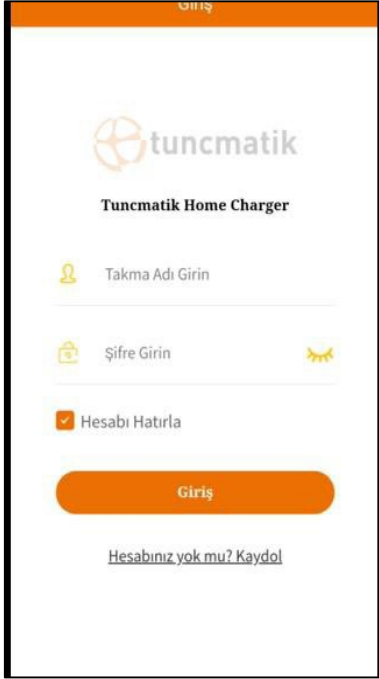

11. ADIM: T-Charger uygulamasını açın ve hesabınızdan giriş yapın.

12. ADIM: Ekranınızın aşağısında yer alan KİŞİSEL ALAN kısmına basıp OK ile gösterilen Şarj Pili Ağ Kurulumu yerine tıklayın.

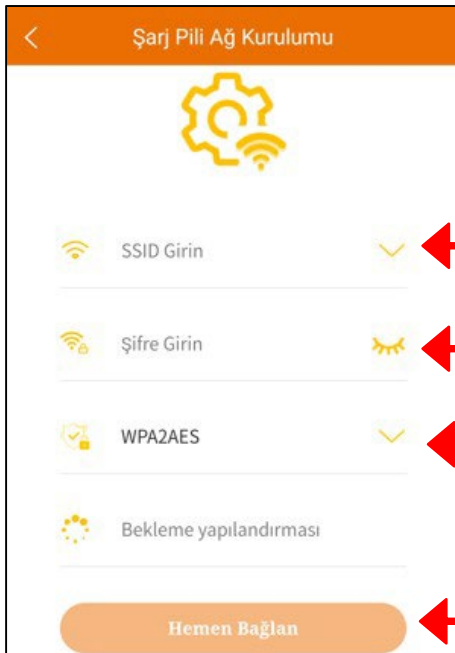

13. Bağlantı yapmadan önce KONUM açın. Bu sizlerin etrafınızda bulunan Wİ-Fİ noktalarını görmeyi sağlar.

1) İlk kısımda WİFİ adınızı yanda OK simgesine tıklayarak buluyoruz ve işaretliyoruz.

2) Ardından seçmiş olduğumuz WİFİ adresinin WİFİ şifresini giriyoruz.

3) WPA2AES kısmı seçili olacak.

4) Hemen Bağlan butonuna bastıktan sonra Yapılandırılmanın onayı geldikten sonra çıkıyoruz.

Bağlantı TAMAM yazısı geldikten sonra geri dönün.

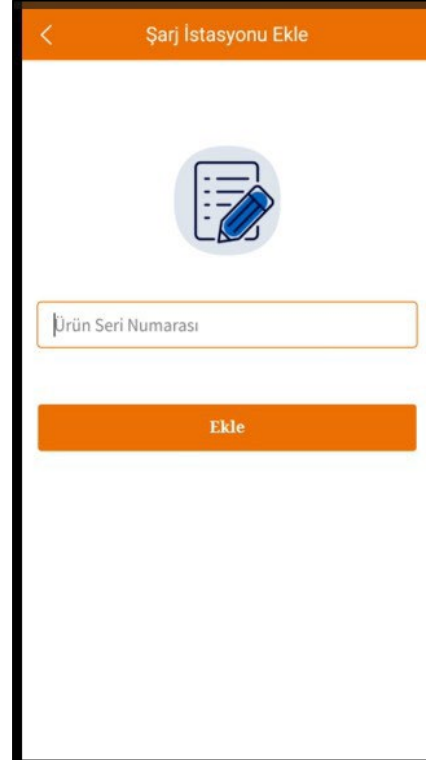

14. ADIM: Cihazımızı sisteme kaydetmek için şimdi Şarj İstasyonu Yönetimine tıklayın.

15. ADIM: Cihazınızın SERİ numarasını girin. Ardından bağlantı kurulduktan sonra ANA SAYFADAN cihazınızın verilerini ve şarj geçmişi, şarj değerlerini görebileceksiniz.

ÖNEMLİ: Veri bağlantısı kurulamıyor ise MY- CHARGER cihazınızın Wi-Fi bağlantısının sağlıklı yapıldığından emin olmanız gerek. Wi-Fi bağlantısını tekrardan yapmanız gerekecektir.

6.2 Cihazın İnternete Bağlanması

1. Cihazımıza ilk olarak enerjiyi veriyoruz.
2. Cihazın Wİ-Fİ bağlantısına Telefon ile bağlanıyoruz.
3. Cihazın Wİ-Fİ adı: HI-LINK ile başlayan Wİ-Fİ adıdır. Şifre: 12345678
4. Tarayıcıya 192.168.16.254 yazın, kullanıcı adı ve parolayı girmek için bir iletişim kutusu açılacaktır. Hem kullanıcı adı hem de şifre **admin**'dir.

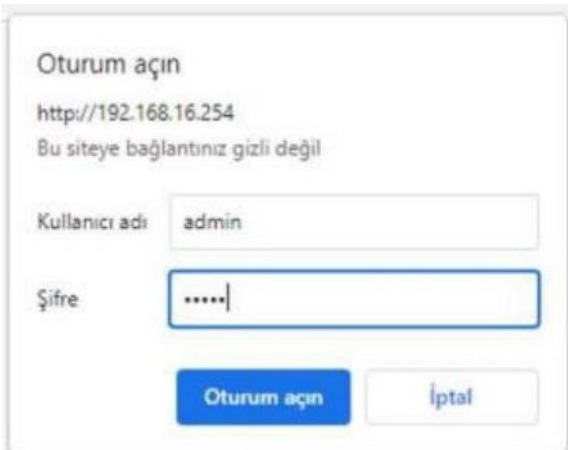

5. Oturum açtıktan sonra parametreleri resme göre ayarlayın.
a. STA SSID kısmına Wİ-Fİ bağlantısını SCAN kısmına basarak bulunacak.

	Current	Updated
Network Mode	AP Client	AP Client
STA SSID		Scan
STA EncType	WPA2AES	WPA2AES
STA Passwd		
IP Type	DHCP	DHCP
AP Enable	Enable	Enable
AP SSID	HI-LINK_1343	HI-LINK_1343
AP EncType	WPA2AES	WPA2AES
AP Passwd	12345678	12345678
LAN IP Addr	192.168.16.254	192.168.16.254
LAN Mask	255.255.255.0	255.255.255.0
DHCP Server	Enable	Enable

6. SCAN kısmına basında çevrede bulunan bütün Wİ-Fİ isimleri görülecektir. Bu kısımdan seçmek istediğiniz Wİ-Fİ adresinin ismini kopyalayıp STA SSID kısmına yapıştıracağız.
7. Security kısmını kontrol edip bağlantının güvenlik tipini de ayarlamamız gerekecek.
8. Örnekte verildiği gibi **tuncmatik_deneme** Wİ-Fİ adresini kullanacağız.

Refresh Close

Scan AP List							
Ch	SSID	BSSID	Security	Signal(%)	W-Moe	ExtCh	NT
3	tuncmatik_deneme_3	8c:59:73:2a:a1:f1	WPA1PSK/WPA2PSK/TK/AES	13	11b/g/n	NONE	In
6	tuncmatik_deneme	40:d6:3c:66:f7:ad	WPA2PSK/AES	78	11b/g/n	NONE	In
6	tuncmatik_deneme_3	40:d6:3c:79:41:fb	WPA2PSK/AES	44	11b/g/n	NONE	In
6	tuncmatik_deneme_4	40:d6:3c:65:fb:c1	WPA2PSK/AES	70	11b/g/n	NONE	In

9. STA SSID kısmına bağlanmak istediğimiz Wİ-Fİ adını yazıyoruz. Bunun için SCAN tuşuna basıp arama yapıyoruz ve ardından bağlanmak istediğimiz Wİ-Fİ bağlantısının adını kopyalayıp CLOSE tuşuna basıp Ana Menüde yer alan STA SSID kısmına kopyaladığımız Wİ-Fİ adresin ismini buraya yapıştırıyoruz.

Örnek: STA SSID: tuncmatik_deneme

Ch	SSID
3	tuncmatik_deneme_3
6	tuncmatik_deneme
6	tuncmatik_deneme_3
6	tuncmatik_deneme_4

10. STA EncType kısmına SCAN kısmındaki Wİ-Fİ bağlantımızı seçerken yan tarafında yer alan SECURITY kısmındaki koruma tipini gireceğiz.

Örnek: STA EncType: WPA2AES



11. STA Passwd kısmına bağlantısını yapmak istediğimiz Wİ-Fİ adresin şifresini girmemiz gerekiyor. Örnek: STA Passwd: 1234567890

12. Doldurmamız gereken kısım KIRMIZI alan içerisinde gösterilmiştir.

a. Geri kalan alanları da aşağıdaki resimde yer alan Updated kısmından kontrol edin.

	Current	Updated
Network Mode	AP Client	AP Client <input type="button" value="Scan"/>
STA SSID		tuncmatik_deneme
STA EncType	WPA2AES	WPA2AES
STA Passwd		1234567890
IP Type	DHCP	DHCP
AP Enable	Enable	Enable
AP SSID	HI-LINK_1343	HI-LINK_1343
AP EncType	WPA2AES	WPA2AES
AP Passwd	12345678	12345678
LAN IP Addr	192.168.16.254	192.168.16.254
LAN Mask	255.255.255.0	255.255.255.0
DHCP Server	Enable	Enable

13. AP SSID ve AP Passwd sizlerin sahip olduğu MY Charger olmaktadır. Burada ve LAN IP Addr ve LAN Mask kısımlarında herhangi bir değişiklik yapılmayacaktır.

14. Onaylama verildikten sonra biraz bekleyin.

6.3 TUNÇMATİK HOME CHARGER UYGULAMASI

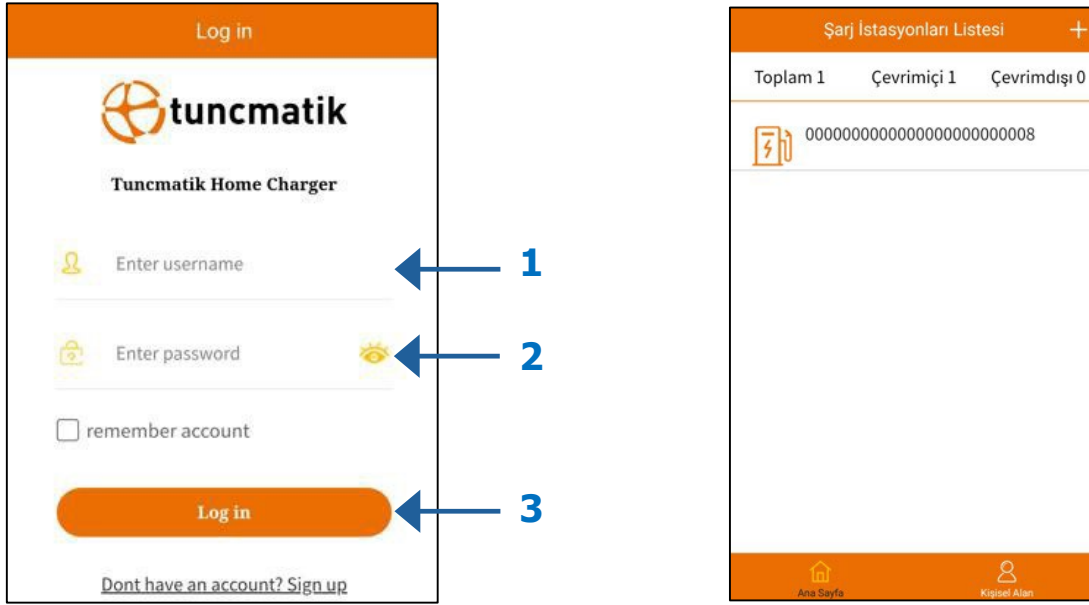

1. telefonunuzu MY CHARGER'ın WİFİ adresine bağlanıyoruz. Ardından uygulamayı açıyoruz.
2. Bu kısımda uygulamadaki kullanıcı adınızı ve şifrenizi oluşturup giriş yapılacaktır. Kullanıcı adınızı 1 ile gösterilen girilecek. Kullanıcı adınızı belirledikten sonra 2 ile gösterilen yere şifrenizi oluşturmanız gerekecek. Kullanıcı adınız ve şifrenizi belirledikten sonra 3 kısımdaki yere dokunup giriş yapabileceksiniz
3. Hesabınıza otomatik giriş yapmak için (REMEMBER ACCOUNT) ya da Hesabımı hatırla kısmınıza basmanız yeterli olacaktır.
4. Giriş yapıldıktan sonra görselde yer alması gereken olan cihazınızı SERİ NUMARASINI uygulamaya tanıtmanız ve kaydetmeniz gerekiyor.
(Yukarıda yer alan cihaz seri numarası örnek teşkil etmektedir)



5. Bir ve daha fazla MY CHARGER kaydetmesi de yapabilirsiniz



6. KİŞİSEL ALAN yazılı kısmıyoruz.

7. Şarj İstasyonu Yönetimi kısmından isteğe bağlı olarak kayıtlı olan şarj istasyonunuzu silebilirsiniz.

a. Örnekte olduğu gibi 9 numaralı Şarj İstasyonunu sistemden sildik.

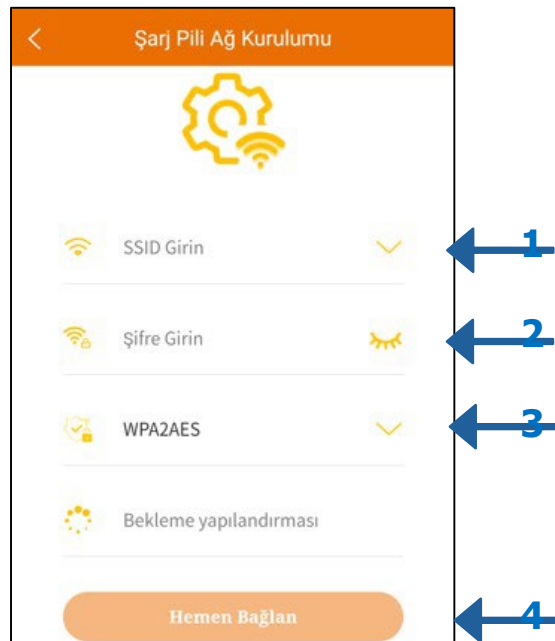

8. KİŞİSEL ALAN yazılı kısma geri geliyoruz. Buradan gösterilen yere Şarj Pili Ağ kurulumuna basıyoruz.

9. Bağlantı yapmadan önce KONUM açın. Bu sizlerin etrafınızda bulunan Wİ-Fİ noktalarını görmeyi sağlar.

10. İlk kısımda WİFİ adınızı yanda OK simgesine tıklayarak buluyoruz ve işaretliyoruz.

11. Ardından seçmiş olduğumuz WİFİ adresinin WİFİ şifresini giriyoruz.

12. WPA2AES kısmı seçili olacak.

13. Hemen Bağlan butonuna bastıktan sonar Yapılandırılmanın onayı geldikten sonra çıkıyoruz.



14. Cihazımız WİFİ bağlantısı sağladıktan sonra şarj etmek istediğimiz araca fişi takip ana menüdeki cihazımıza tıklıyoruz.

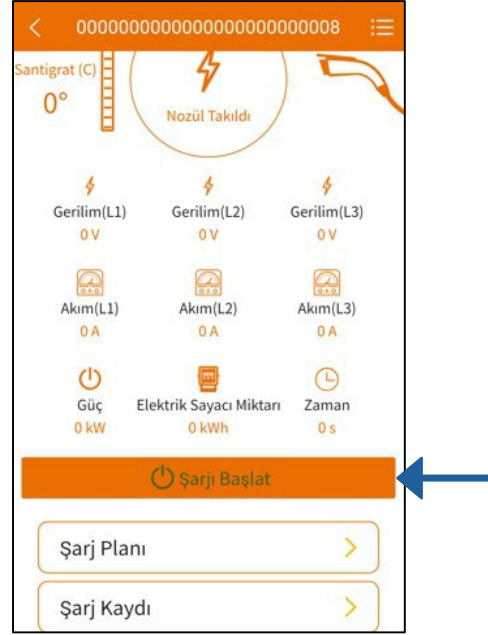

15. Şarj işlemini ve değerleri bu sayfadan takip edilecek.

16. ŞARJI BAŞLAT kısmına bastığımızda şarj işlemi başlayacaktır.



17. Şarj işlemini bitirdikten sonra şarj ile ilgili detaylar sizlere görseldeki gibi gösterilecektir.



18. Şarj Kaydı kısmından önceden yapmış olduğunuz Şarj işlemlerini takip edebilirsiniz.



19. Yandaki görselde önceden yapılmış olan şarj işlemleri yer almaktadır.

6.4 PLANLI ŞARJ NEDİR, NE İŞE YARAR?



1. Randevulu Şarj işlemi yapmak için Şarj Planı kısmına basıp saat ayarlaması yapabilirsiniz.

- 1) Planlı (Rezervasyonlu) Şarj işlemi yapmak kullanıcıya istediği zaman şarjı başlatıp istediği zamanda bitirme olanağı tanımaktadır.
- 2) İstenildiği saat dilimleri arasında şarj işleminizi yapabileceksiniz.
- 3) Alternatif olarak istediğiniz saat diliminde şarjınızı başlatıp TAM DOLUM yapana kadar şarj işleminizi yapabileceksiniz.



2. Planlı (Randevulu) Şarj işlemine başlamak için aracımıza fişi takıyoruz. Ve Şarj Planı kısmına geliyoruz.
3. Şarj yapılacak zamanı Başlama Zamanı ve Bitir Zamanını ayarlıyoruz. Ardından KAYDET tuşuna basıyoruz.
4. Rezerve yaptığımız Şarj aralığını resimde görebiliyoruz.
5. Başlama zamanı geldiğinde Şarj işlemi otomatik olarak başlayacak, Bitiş zamanı geldiğinde de otomatik olarak Şarj işlemi duracaktır.
6. Şarj geçmişinizi görüntülemek için Şarj Kayıtları kısmından takip edilebilir.

6.5 Yazılım Güncellemesi ve Akım Ayarlaması



1. Şarj işlemlerimizi takip ettiğimiz sayfanın SAĞ ÜST kısmında yer alan simgeye tıklayarak yazılım güncellemelerini ve akım ayarlamalarını kontrol edebiliriz.
2. Şarj işlemlerimizi takip ettiğimiz sayfanın SAĞ ÜST kısmında yer alan simgeye tıklayarak yazılım güncellemelerini ve akım ayarlamalarını kontrol edebiliriz.
3. İsteğe bağlı olarak Akım değerini buradan ayarlıyoruz ve Firmware güncellemesini buradan kontrol edebiliriz.

6.6 SWITCH AYARLAMA

Uygulamalı yöntemler ve Wi-Fi ayarlamalarından hiçbiri Cihazınız ve Telefonuz arasında bir bağlantı sağlayamadıysa cihazınızın içini açıp aşağıda yer alan resme bakarak switch ayarlamasını yapın. Yapacağınız bu ayarlama cihazınızı Wi-Fi moduna alacaktır. Ayarlamaları yaptıktan sonra işlemleri tekrar edebilir ve bağlantınızı ve uygulamanızı kesintisiz bir şekilde kullanabilirsiniz.

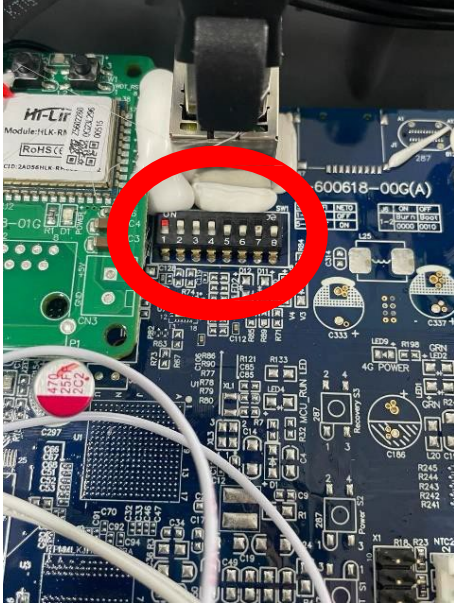

1. Resimde halka içersinde gördüğünüz gibi SWITCH'ler toplam 8 tanedir.
2. Wi-Fi moduna almak için 1-2-3-4 ON konumuna (YUKARI KONUM) olacak, 5-6-7-8 OFF konumuna (AŞAĞI KONUM) olacak.

7. Screen Image

1. After power on, the machine screen will display the startup screen, as shown in the following image:



2. After about 5 seconds, the screen will automatically switch to the scanning interface, as shown in the following image:

Note: The images displayed on ATP III 6507W/11W and ATP III 65021W screens may be different, and the same applies below.



ATPⅢ 6507W/11W



ATPⅢ 65021W

3. When charging, the screen will display the following interface based on the charging status:

1) Charging in progress:

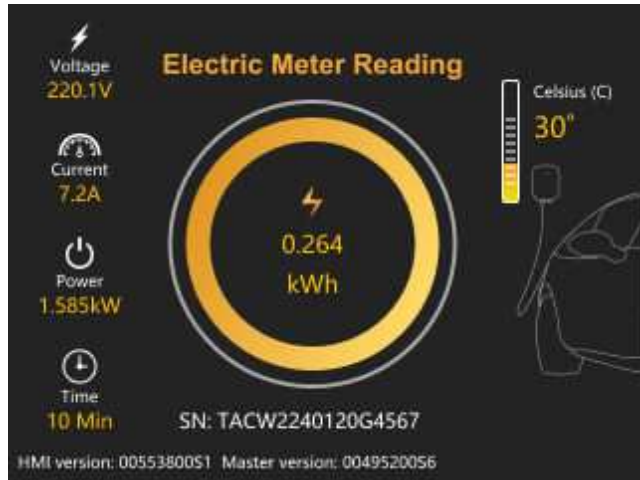

ATPIII 6507W/11W

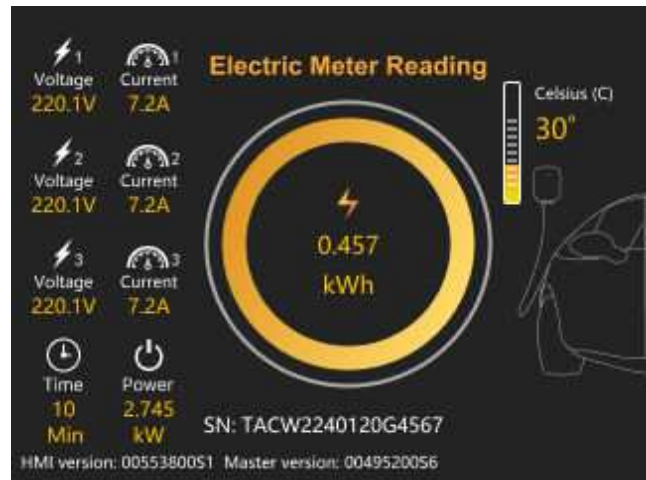

ATPIII 65021W

2) Fully charged:

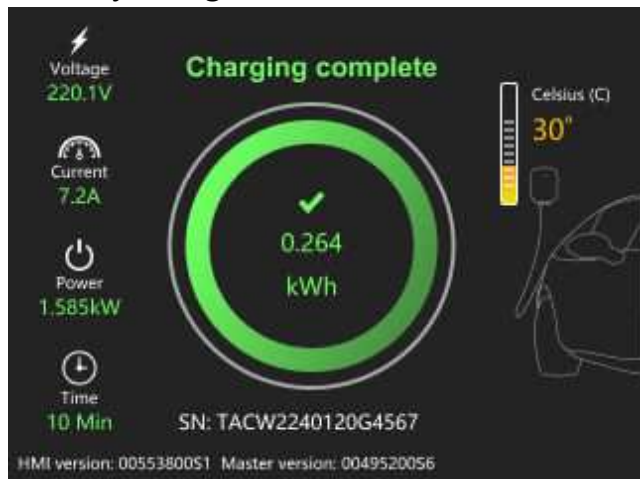

ATPIII 6507W/11W

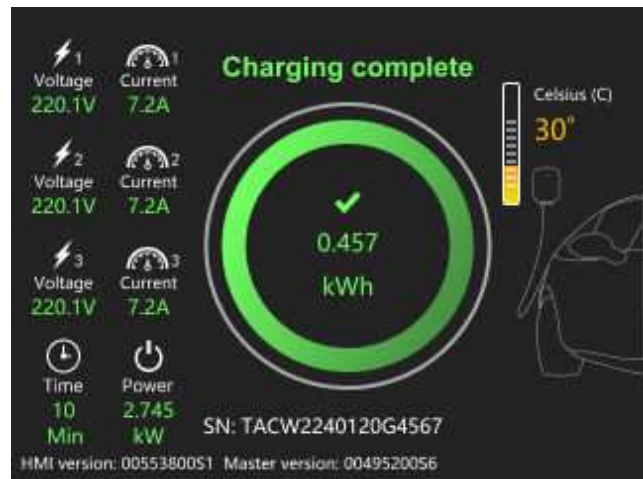

ATPIII 65021W

4. When the charging station malfunctions, the following interface will be displayed:





8. Routine Maintenance

Due to the influence of ambient temperature, humidity, dust and vibration, the internal devices of the charger will wear out, which leads to the potential failure of the charger. Therefore, it is necessary to carry out daily and regular maintenance of charger to ensure their normal operation and its service life.

- Regularly check if the cabinet structure is loose and sliding.
- Check if the connecting wire is worn and the charging connector is connected firmly.
- Regularly check if any internal components is damage, loose or burned out.
- Regularly check if AC incoming line and ground wire are firmly connected.
- Check the dust accumulation in the cabinet once a month and clean it in time to ensure the heat dissipation.
- Please be sure to keep the cabinet door closed and locked when nobody is on duty.

NOTE: Only professional electricians or persons with professional qualifications can operate the contents of this chapter.

	CAUTION: Do not leave screws, washers and other metal parts in the charger for maintenance, otherwise the equipment may be damaged. After the completion of equipment maintenance, it is necessary to check the cabinet to ensure the normal operation of the charger.
	WARNING: During equipment maintenance and overhaul, please be sure to cut off the AC side power supply of the charger.
	WARNING: During equipment maintenance, necessary measures shall be taken to prevent the charger from being energized by mistake.

Maintenance Item	Maintenance Cycle
Check the cable and connection regularly, check whether all the cable connection is loose, if loose, must be tightened; Check connection terminals and insulation for discoloration or peeling, replace damaged or corroded terminals, and replace damaged cables.	3 months
Check whether the warning label is firm or clear, and replace it accordingly.	3 months
Regularly check whether there is abnormal sound during the operation of the charger.	3 months
Check the emergency stop function regularly: check whether the emergency stop switch is normal.	3 months

NOTE: If the charger is used in a harsh environment, please carry out routine cleaning according to the actual usage.

9. Trouble Shooting

Display Information	Trouble Shooting
PE loss	Please check if PE is lost
AC input overvoltage	check input voltage
AC input under voltage	check input voltage
Utility frequency out of range	Check if the frequency exceeds the rated range
Meter fault	Please contact after-sales service
Output over current	Please contact after-sales service
Pile over temperature	Please contact after-sales service
Relay fault	Please contact after-sales service
Insulation fault	Please contact after-sales service
Guide voltage anomaly	Please contact after-sales service